



EATON

Aerospace

**Centurion™ Brand
Mechanical Seals**



Eaton's Centurion Brand Mechanical Seals

The Advantages of Choice

Eaton's Aerospace Operations offers the most diverse line of mechanical seals and sealing components, including pressure-balanced face seals, circumferential segmented seals, brush seals and welded metal bellows seals. Each incorporates the optimum seal configuration, material and technology, including hydrodynamics; which can be applied to both face and circumferential seals, significantly improving performance. Rather than offer one product, Eaton possesses hundreds of solutions to sealing problems. Eaton can also custom-design and fabricate exactly what you need.

The Advantages of Experience

Eaton's products are installed on every aircraft in the world, and on virtually every missile, satellite, space shuttle, and weapon system. And we service our products. Eaton's Centurion brand seals are regularly repaired and overhauled at our FAA licensed repair facility in Warwick, RI (FAA Repair Station VJPR395K). Airlines worldwide rely on Eaton to perform overhaul and repair on aircraft seals at our FAA repair station.

Our experience has been proven in severe applications, which translates into better performance. Whether conventional or complex, Centurion brand mechanical seals are used in auxillary power units (APUs), compressors, power generating gas turbines, aircraft engines, engine starters, fuel controls, gearboxes, engine accessories, nuclear valves, production machinery equipment, off road vehicles, and turbochargers at both high and low speeds, pressures and temperatures.

Welded metal bellows seals help to reduce hysteresis and secondary seal deterioration in APU compressors, small gas turbines and fuel controls while extending the mean time between overhauls (MTBO). The welded bellows secondary seal offers unique, high value advantages over conventional elastomeric secondary seals.

The Advantages of a Strong Engineering Team

Eaton's Centurion brand Mechanical Seals are supported by an Engineering Team, Metrology Department and a sophisticated R&D Laboratory. By leveraging the expertise of technical teams, Eaton is capable of supporting customers in various ways:

- Optimizing seal performance for specific applications
- Testing seals both statically and dynamically
- Analyzing customer hardware and Researching new seal technologies to en-

hance product capabilities

- Reducing leakage and extend life

Eaton's team is dedicated to not only designing the most reliable seals for any application, but also supporting the products installed over the life of the application.



Centurion brand Segmented Mainshaft Seal

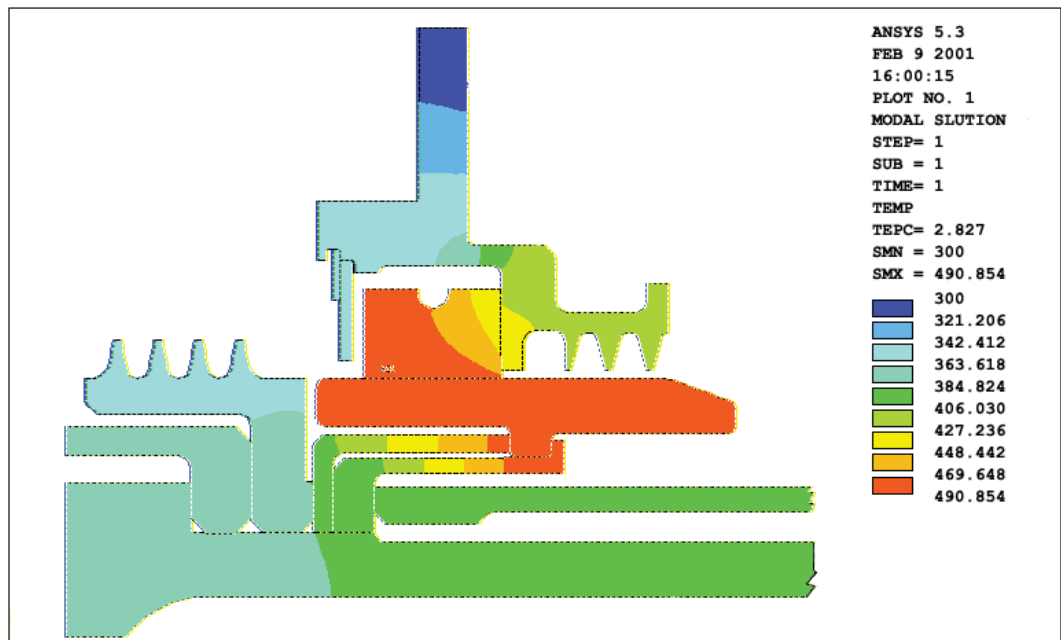

A finite element analysis of a circumferential seal and rotor for an aircraft gas turbine application.

Centurion Brand 700 Series Mechanical Seals

Eaton's Centurion brand 700 Series mechanical seals are stationary, "face" type seals designed for a wide array of applications: from aircraft engine accessory gearboxes and mainshafts to hydraulic pumps, starters, compressors, industrial generators and other high speed, rotating machinery. Although typical designs range in types managing high speed, large axial movement or high pressure applications, there are mainly two types of 700 Series seals: the monoblock carbon type and the metal-backed type (see Figure 1). Standard sizes exist for shaft diameters from 0.25" (6 mm) to 3.0" (75 mm). The monoblock seal is recommended in applications where speeds are high, axial movement is moderate to high, and pressures are low. The metal-backed seal is recommended in high pressure, low speed applications, and where axial movement is moderate.

The Centurion brand 700 Series seal can be tailored to meet specific application conditions. For example, seals may accept face or reverse pressure. They can accommodate exposure to corrosive fluid media such as Skydrol. Seals are "balanced" to handle high speed or high pressure applications. The carbon-graphite sealing element (stator) is selected as a function of operating conditions and type of available lubrication. Under moderate speed and temperature conditions, 700 Series seals can operate satisfactorily with an oil mist or oil splash environment. Under some operating conditions, seals can be configured to operate dry-running, i.e., with minimal oil mist, spray or jet, with the proper selection of interfacing materials, design and seal balance.

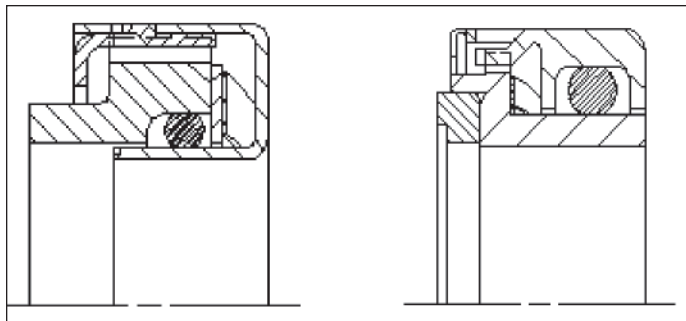

Centurion brand 700 Series Mechanical Seals cross-section (monoblock and metal backed versions)



Centurion brand 700 Series Seal (monoblock version)

700 Series Seal Performance

700 SERIES SEAL	UNBALANCED FACE	BALANCED FACE	SPECIAL DESIGN
Size (English)	0.375" to 12.0"	0.375" to 12.0"	0.375" to 12.0"
Size (Metric)	10 to 300 mm	10 to 300 mm	10 to 300 mm
Speed (English)	300 feet / second*	300 feet / second*	300 feet / second*
Speed (Metric)	100 m/s*	100 m/s*	100 m/s*
Pressure (English)	150 PSID*	375 PSID*	1500 PSID*
Pressure (Metric)	10 bar*	25 bar*	100 bar*
Temperature (English)	-65 to 350°F	-65 to 350°F	-65 to 350°F
Temperature (Metric)	-50 to 175°C	-50 to 175°C	-50 to 175°C
Leakage (English)	0.05 to 0.15 cu in/hr	0.05 to 0.15 cu in/hr	Negligible
Leakage (Metric)	1 to 3 cc/hour	1 to 3 cc/hour	Negligible
Life	10,000 hours**	10,000 hours**	15,000 hours**
Comments	Special designs include hydrodynamic seals. By incorporating hydrodynamic technology into face seals a step change in life and performance can be realized. Hydrodynamic seals (which are non-contacting) ride on film of air therefore heat generation is essentially eliminated. The result is a seal that can survive or even thrive at conditions typically well beyond those of typical contact seals.		

* Not simultaneously

** Seal Life is a function of operating parameters. The life provided herein is for reference only. For specific applications consult with Eaton Engineering.

Mating Rings For Face-Type Seals & Runners For Circumferential Seals

Face-Type Seals for Large Engine Mainshafts

Centurion Brand Mating Rings for Face-Type Seals and Runners for Circumferential Seals



Mating Ring

Good seal performance is provided by a properly configured stator (seal) mated to a high quality, tightly toleranced rotor (mating ring or runner). Therefore, Eaton's Centurion brand seals should be accompanied by mating rings or rotors designed and fabricated by Eaton. Like the carbon-graphite seal face in our face seals, the associated mating ring must be extremely flat (typically 2 to 3 Helium light bands or 0.000022 to 0.000033 inches—0.6 to 0.9 mm) and possess a smooth finish (4 Ra - 0.1 micrometers).

Mating rings must be retained on a shaft in a manner that prevents slippage, leakage, and distortion. It must also be properly aligned with sources of lubrication, and are often "balanced." Likewise, circumferential seal rotors must be round, smooth and balanced. They can be optimized to minimize coning, and in some cases may require spin testing. Some rotors require hydrostatic or hydrodynamic geometry to either aid in lifting off or suctioning down its seal ring.



Hydrodynamic Mating Ring

Materials for rotors must have excellent thermal conductivity and surface hardness. In some cases coatings may be required. Understanding operating parameters for the seal and mating ring set will allow the designer to tailor a solution with the proper design, materials, and coatings.

Centurion Brand Face-Type Seals for Large Engine Mainshafts



Centurion brand Face-Type Seal for Large Engine Mainshafts

Face-type seals used on large engine mainshafts are similar in construction to conventional 700 class seals, but have additional characteristics to handle the surface speeds, temperatures and pressures typically required of such applications.

The carbon seal ring stator is housed into a metal carrier and is spring loaded against the mating ring (rotor) by a series of coil springs. Due to the temperature requirements, elastomers are not used. Instead, the secondary seal is one or two piston rings comprised of metal, carbon graphite, or a Teflon® jacketed spring seal. Such large

diameter face seals are usually required to seal high temperature air. At high speeds and pressures, some seals are configured to introduce oil lubrication directly at the interface, and are achieved by a flow of oil introduced through the mating ring. The oil dissipates heat and introduces lubrication at the interface. These seals are referred to as

a "wet" face configuration.

Eaton's Centurion brand face-type seals are used to protect bearing sumps from hot gases at elevated pressure when conventional buffered labyrinth seals either take up too much axial and radial space in the design of the gas turbine mainshaft, are too heavy, or are insufficient to manage the required controlled leakage.

Face-Type Seals for Engine Mainshafts Performance

Size (English)	4" to 20"
Size (Metric)	100 to 500 mm
Speed (English)	400 feet / second
Speed (Metric)	120 m/s
Pressure (English)	150 PSID
Pressure (Metric)	10 bar
Temperature (English)	800°F
Temperature (Metric)	425°C
Leakage (English)	<3.0 SCFM
Leakage (Metric)	<0.6 g/s
Life	Function of operating parameters. Consult with Eaton Engineering.
Comments	Hydrodynamic technology can be incorporated into mainshaft face seals. By incorporating hydrodynamics a step change in life and performance can be realized. Hydrodynamic seals (which are non-contacting) ride on film of air therefore heat generation is essentially eliminated. The result is a seal that can survive or even thrive at conditions typically well beyond those of typical contact seals.

Face Temperature
Face Mounted TC Output
Altitude (37,000') Test
Best/Worst Comparison

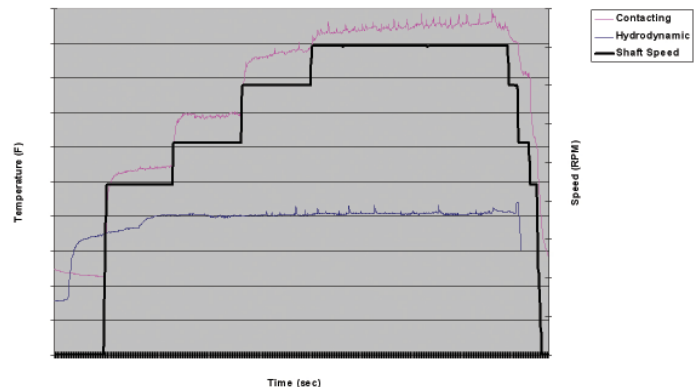

Benefits of hydrodynamic vs. contacting seals

Centurion 800 Series Mechanical Seals

Eaton's Centurion brand 800 Series mechanical seals are stationary, "face" type seal with an all-metallic construction. Originally designed for extreme environmental applications, the 800 Series has found its way into a wide array of applications: from fuel controls, auxillary power units and small aircraft engine gas turbine mainshafts, to helicopter gearboxes, to cryogenic turbopumps and nuclear valves and systems.

The 800 Series welded metal bellows seal shown is comprised of a carbon-graphite-sealing element held in a low-expansion alloy carrier. The carrier is welded to a series of alternating welded stamped diaphragms, which perform as both a hermetic secondary seal and a spring for the mechanical seal. The effective diameter of the bellows acts as the seal's balance diameter. The bellows produce a low spring rate and allow the seal to operate over a long axial operating length while producing a very controlled mechanical load. For seals required to function in applications of high pressure, bellows plates can be configured to control effective diameter (ED) shift, controlling pneumatic loads produced on the sealing interface.

Considerations are made for system vibration in bellows design. The loading provided by the bellows can be precisely controlled in a manner which produces a low hysteresis — lower than most spring-loaded mechanical seals. In applications with high runout, the 800 Series seal face (stator) tracks its mating ring (rotor) well, maintaining contact and

preventing leakage. In conventional seals, higher hysteresis (accompanied by high stator mass) tends to prevent appropriate contact of stator in rotor under such severe conditions.

Bellows seals can be constructed from any weldable material, and can therefore be designed for compatibility with virtually any media. The most popular materials for welded metal bellows seals include: AISI 316L, 347, precipitation hardenable materials such as AM350, AM350 SCT, Titanium, high nickel alloys such as Inconel 718, Inconel X750, and Hastelloys. Due to its all-metallic construction, the 800 Series seal is perfect for applications requiring tightly controlled loads to manage heat generation or in highly caustic fluid media conditions.

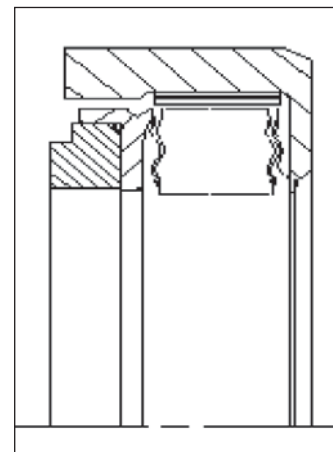

800 Series Seal Performance

Size (English)	0.375" to 10.0"
Size (Metric)	10 to 250 mm
Speed (English)	400 feet/second*
Speed (Metric)	140 m/s*
Pressure (English)	375 PSID
Pressure (Metric)	25 bar*
Temperature (English)	-400 to 1100°F*
Temperature (Metric)	-250 to +600°C*
Leakage (English)	Negligible
Life	20,000 hours**
Comments	Applications with high differential pressure may require special plate configurations and/or 2-ply bellows configurations. Seal is temperature limited solely by the carbon graphite sealing element. Consult with Eaton Engineering.

* Not simultaneously

**Seal Life is a function of operating parameters. The life provided herein is for reference only. For specific applications consult with Eaton Engineering.

1200 Series Circumferential Segmented Seals

Centurion Brand 1200 Series Circumferential Segmented Seals

In addition to face type seals as previously described, many aircraft and industrial gas turbines apply circumferential segmented seals in severe environment applications requiring high reliability and long life in. Segmented carbon seals are also used as barrier seals in industrial compressors. Such seals are ideal in applications where long axial movements are anticipated due to thermal or mechanical phenomena usually found in today's rotor-machinery systems. Typical sizes range from shaft diameters of 1.6" (4 mm) to 10.0" (250 mm).

Circumferential segmented seals are comprised of a series of segmented carbon rings, which are configured to contact the shaft or runner (rotor). These segments are contained within a seal housing, then locked into position with anti-rotation keys or pins. A secondary seal is formed by the axial spring loading of the seal rings against the finely machined internal surface of the housing. A garter spring contains the segments together and applies the circumferential load at the dynamic sealing interface. A unique joint configuration at each end of the segments results in a minimal leakage at each joint. The segments are pressure relieved to control actual contact loads, both axially and radially, and are configured so that during transient movement, a continuous sealing dam is always in contact with either the primary or secondary sealing surfaces.

Circumferential seals are designed for sealing gases, and are often designed in a gas buffered tandem arrangement when sealing an oil or

other liquid. In the presence of a liquid, seal ring segments are subject to lift open due to viscous effects, unless a special design is applied which would allow the seal ring segments to close the seal at its interface using such features as hydrodynamic geometry.

As most circumferential-segmented seals are contacting seals, the frictional heat generated by the runner and carbon at high sliding speeds must be dissipated by an appropriate cooling method. The usual methods involve directing a flow of oil at, on or under the runner.

The most common application for Eaton's Centurion brand 1200 Series seals are as mainshaft seals for state-of-the-art aircraft gas turbine engines, but other applications include compressor barrier seals (which act as a backup to high pressure, non-contacting gas seals) used in modern compressors, and in blowers, mixers and separators. Aircraft seals occasionally require such design enhancements as housing windbacks, a screw-like visco seal which restricts oil at the primary sealing interface; windage screens, which attempt to keep oil to the outside and air to the inside of the sealing system; and choppers, which fling oil to the outside surfaces away from the sealing interface.

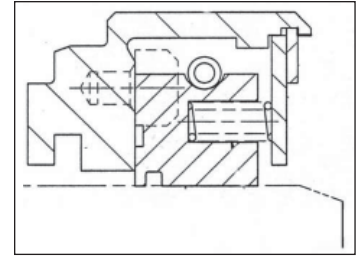

1200 Series Seal Performance

CENTURION BRAND 1200 SERIES SEGMENTED SEAL	CONTACTING CIRCUMFERENTIAL SEGMENTED SEAL	ARCH-BOUND CIRCUMFERENTIAL SEGMENTED SEAL
Size (English)	1.6" to 10.0"	0.375" to 12.0"
Size (Metric)	40 to 250 mm	40 to 125 mm
Speed (English)	400 feet / second	800 feet / second
Speed (Metric)	120 m/s	240 m/s
Pressure (English)	90 PSID	90 PSID
Pressure (Metric)	6 bar	6 bar
Temperature (English)	-65 to 950°F	-65 to 900°F
Temperature (Metric)	-50 to 500°C	-50 to 500°C
Leakage (English)	Consult with Eaton Engineering	Consult with Eaton Engineering
Leakage (Metric)	Consult with Eaton Engineering	Consult with Eaton Engineering
Life	>8000 hours*	>8000 hours*
Comments	Hydrodynamic technology can be incorporated into welded metal bellows face seals. By incorporating hydrodynamics a step change in life and performance can be realized. Hydrodynamic seals (which are non-contacting) ride on film of air therefore heat generation is essentially eliminated. The result is a seal that can survive or even thrive at conditions typically well beyond those of typical contact seals.	

*Seal Life is a function of operating parameters. The life provided herein is for reference only. For specific applications consult with Eaton Engineering.

Eaton Centurion 1900 Series Brush Seals

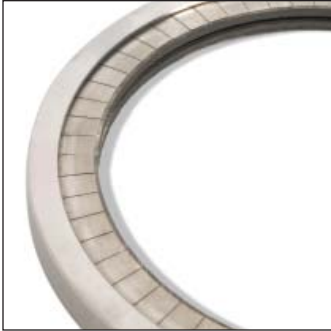

Brush seals made of high temperature nickel-cobalt alloy bristles are circumferential seals which may be used in place of traditional labyrinth seals in large or small gas turbine secondary and tertiary flow gas paths. Low-hysteresis damping plates allow seals to withstand large radial movements without opening, allowing the seals to manage high temperature, high-speed environments with long life capabilities.

Brush seals are comprised of an array of densely packed, high temperature resistant, low wear bristles, configured on an angle of approximately 45 degrees with the tangent of its adjacent shaft. The bristles form a flexible porous medium, controlling leakage from 1/5 to 1/3 of typical labyrinth seal leakage. The seal takes up slightly more radial room than a conventional straight toothed labyrinth, but takes up significantly less axial space, and weighs far less than machine labyrinths.

Brush seals are being applied in today's gas turbines as replacement for labyrinth, other air to air seals and oil seals to improve engine efficiency, reduce fuel consumption and increase engine thrust.

Eaton Centurion 1300 Series Clearance Seals

Clearance seals are circumferential non-contacting seals, which are free to move radially to track transient excursions over the shaft to which it is applied. Much like the 1200 Series seal, this circumferential seal also uses a precision machined housing which, when interfacing with the seal ring, acts as a secondary sealing element. The clearance seal is ideal for applications with large axial and small radial movements.

The primary seal ring is comprised of a high temperature carbon-graphite, pressed and stabilized into a metal band or carrier. The resulting assembly is called a "composite."

The band of the composite is selected to match the coefficient of thermal expansion of the shaft, and by doing so controls leakage through the seal over most operating conditions. The seal ring is designed for a very small, controlled clearance, producing a controlled but acceptable leakage between the seal's tightly tolerated inside diameter, and the diameter of the runner or shaft. The composite hunts for a steady state position during shaft excursions.

Since clearance seals are non-contacting, they can withstand high surface speeds; and since they are made of metal and carbon-graphite, the temperature limitation on the seal is dictated by the materials selected.

Clearance seals are superior to labyrinth seals since they allow more seal flexibility, and their design allows the seal to accommodate larger radial movements without seal degradation. Leakages are usually an order of magnitude lower than labyrinth seals. They are excellent for sealing hot gases from bearings and other critical components in rotating equipment.

The envelope required is small, compact and low on mass. Clearance seals are used adjacent to turbine and compressor bearings in small gas turbines and power units, as well as buffered low temperature applications such as one for a LOX turbopump.



1900 Series Brush Seals Performance

Size (English)	1.6" to 60"
Size (Metric)	40 mm to 1.5 M
Speed (English)	1200 feet / second
Speed (Metric)	365 m/s
Pressure (English)	Up to 300 PSID per stage
Pressure (Metric)	Up to 20 bar per stage
Temperature (English)	1200°F
Temperature (Metric)	650°C
Leakage (English)	Consult with Eaton Engineering
Leakage (Metric)	Consult with Eaton Engineering
Life*	Consult with Eaton Engineering

*Seal Life is a function of operating parameters. The life provided herein is for reference only. For specific applications consult with Eaton Engineering.

1300 Series Clearance Seal Performance

Size (English)	0.375" to 6.0"
Size (Metric)	10 to 150 mm
Speed (English)	800 feet/second
Speed (Metric)	240 m/s
Pressure (English)	90 PSID
Pressure (Metric)	6 bar
Temperature (English)	-400 to 1200°F
Temperature (Metric)	-250 to 650°C
Leakage (English)	Consult with Eaton Engineering
Leakage (Metric)	Consult with Eaton Engineering
Life	>8000 hours*

*Seal Life is a function of operating parameters. The life provided herein is for reference only. For specific applications consult with Eaton Engineering.

Eaton Corporation
Conveyance Systems Division
300 South East Avenue
Jackson, Michigan 49203-1972
Phone: (517) 787-8121
Fax: (517) 787-5758

Eaton Corporation
Conveyance Systems Division
Route 2 Box 361
Meadowbrook Road
Eastanollee, Georgia 30538
Phone: (706) 779-3351
Fax: (706) 779-2638

Eaton Corporation
Conveyance Systems Division
11642 Old Baltimore Pike
Beltsville, Maryland 20705
Phone: (301) 937-4010

Eaton Corporation
Conveyance Systems Division
15 Pioneer Ave.
Warwick, Rhode Island 02888
Phone: (401) 781-4700
Fax: (401) 461-4310

Eaton Corporation
Conveyance Systems Division
671 W. 17th Street
Costa Mesa, California 92627
Phone: (949) 548-3421
Fax: (949) 752-2997

Eaton LTD
Conveyance Systems Division
Broad Ground Road
Lakeside
Redditch
Worcs B98 8YS
England
Phone: (44) 152-751-7555
Fax: (44) 152-751-7556

Eaton S.A.
Conveyance Systems Division
2 Rue Lavoisier BP 54 78310
Coignieres, France
Phone: (33) 1-30-69-3000

Eaton LTD
Conveyance Systems Division
Chemin De Pau
64121 Serres-Castet
France
Phone: (33) 559-333-864
Fax: (33) 559-333-865

Eaton LTD
Conveyance Systems Division
Posttack 1026
Carl -Benz-Strasse 9
D-82205 Gilching
Germany
Phone: 49 (0) 8105-750
Fax: 49 (0) 8105-7555

Vickers Systems Pte Ltd
Conveyance Systems Division
Lot 512, Jalan Delima, Batamindo
Industrial Park
Batam 29433, Indonesia
Phone: (62) 611823

