

EAT-N

Aerospace

Aeroquip Fluid Conveyance

Technical Focus

Aeroquip®
Precision Sealing Systems™

**When It Comes to Global
Sealing Applications,
We Know Our Way Around**



Shaft and Face Seals with a Heritage

For over sixty years Eaton's Aeroquip Fluid Conveyance has served global customers with the highest quality products and unmatched customer service.

Included in our heritage is over 45 years of shaft seals and face seals experience. The Aeroquip® Precision Sealing Systems offers a complete line uniquely suited for the aerospace industry.

Applications include:

- Gas turbine engines
- Turbochargers
- High speed gearboxes
- Reactor fueling systems
- High temperature oscillating pneumatic valves
- Air compressors
- Cryogenic test machines
- Hydraulic actuators
- Rocket engine turbo pumps
- Propeller shafts
- Refrigeration compressors
- Aerospace hydraulic pumps

Eaton offers more than just a family of seal/products with outstanding properties. A complete support program goes with every seal order that is made. A support program that can

provide you with these valuable extras:

Total Involvement – We deliver value to your application from start to finish. We help design the seals for your product and help build the system to make it perform the way it was intended. We are experts in every phase of prototype development.

Technical Service – We help choose the right product, the right materials, help get approvals from regulatory bodies, and even perform extensive product analysis testing. Our Quality Control System assures that our products meet or exceed MIL-9858. Every seal we manufacture is subjected to 100% inspection for critical dimensions and includes stringent pressure checks to assure performance. Our continuing technical service includes:

Field Based Technical Service Engineers and Application Development Engineers – To assist in part design and materials selection. The seals shown in this catalog are standard seals. Eaton will provide custom seal designs upon request.

Labs To Test Your Application – Our state-of-the-art facilities have been designed to simulate

working environments for end-use applications. Our services include performance testing in simulated temperature, humidity and chemical environments.

Our total capabilities include:

- Statistical process control to assure quality at each step of the manufacturing process.
- Full record traceability to meet the precise needs of US Government and OEM customers.
- CAD/CAM and modeling systems.
- Finite element analysis.
- CNC machine tools.
- Computer scheduling for placement and tracking of orders.

Every shaft seal and face seal we engineer and manufacture has endured the stringent quality and performance tests that have made Eaton's Aeroquip brand an industry leader. The highest quality products, unequalled service and support from a single, global source. Eaton's Aeroquip Fluid Conveyance. No one offers you more.

When specifying a seal, the Seal Size Number should follow the Series number. A Series B-1045 for a 1.000 shaft would be Part No. B-104516.

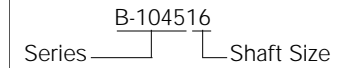

SEAL COMPARISON

SEAL TYPE	SEGMENTED SHAFT	FRACTURED CARBON SHAFT	CONTROLLED GAP SHAFT	FACE (O-RING)	FACE (PISTON RING)	SPLIT HOUSING SHAFT
Leakage	Moderate	Low	High	Low	Low	Moderate
Temperature	High	High	High	Moderate	High	High
Pressure	High	Low to Moderate	Low to Moderate	High	Moderate	Moderate
Speed	Moderate	Moderate	High	Moderate	Moderate	Moderate
Wear	Moderate	Low	Low	Moderate	Moderate	Moderate
Heat Generation	Moderate	Moderate	Low	High	High	Moderate
Cost	Moderate	Low	Low	Moderate	High	Moderate
Axial Movement	High	High	High	Low	Low	High
Radial Movement	Moderate	Low	Low	Moderate	Moderate	Low

Segmented Shaft Seals

Suitable for sealing gases and liquids over a temperature range of -400°F to +1400°F, Shaft Seals are free from thermal and chemical restrictions associated with elastomeric materials since no elastomers are used. Among the features of this seal are its ability to accommodate shaft axial movement, misalignment, shaft runout, compensate for

wear, and seal efficiently both statically and dynamically.

The recommended shaft-mating surface is hard chrome plate with the diameter held to .0005" run out and a surface finish of 8 rms maximum. Other mating materials may be used successfully if a minimum hardness of Rc55 is maintained.

The Series B-1030 Seal is unidirectional in sealing and must be installed with the spring side towards the high pressure so that "P₁" is greater than "P₂". The Series B-1035 Seal is used where pressure reversals take place. The Series B-1040 Seal is a double internally pressurized seal which requires that pressure "P" be greater than both

"P₁" and "P₂". It is typically used to separate incompatible gases or fluids.

A		B		C		D	E	F
SHAFT O.D. +.001/-0.000	SEAL SIZE NO.	SEAL O.D.	HOUSING BORE*	SEAL O.D.	HOUSING BORE*	+0.20/-0.00	+0.20/-0.00	+/-0.10
0.375	06	.8765-.878	.875-.876	1.0015-1.003	1.000-1.001	.250	.500	.062
0.500	08	1.1265-1.128	1.125-1.126	1.2515-1.253	1.250-1.251	.312	.625	.062
0.625	10	1.2515-1.253	1.250-1.251	1.377-1.3785	1.375-1.376	.312	.625	.062
0.750	12	1.377-1.3785	1.375-1.376	1.502-1.5035	1.500-1.501	.312	.625	.062
0.875	14	1.502-1.5035	1.500-1.501	1.627-1.6285	1.625-1.626	.312	.625	.062
1.000	16	1.627-1.6285	1.625-1.626	1.752-1.7535	1.750-1.751	.312	.625	.062
1.125	18	1.752-1.7535	1.750-1.751	1.876-1.8775	1.874-1.875	.312	.625	.062
1.250	20	1.876-1.8775	1.874-1.875	2.002-2.0035	2.000-2.001	.312	.625	.062
1.375	22	2.002-2.0035	2.000-2.001	2.127-2.1285	2.125-2.126	.312	.625	.062
1.500	24	2.252-2.2535	2.250-2.251	2.377-2.3785	2.375-2.376	.375	.700	.125
1.625	26	2.377-2.3785	2.375-2.376	2.502-2.5035	2.500-2.501	.375	.700	.125
1.750	28	2.502-2.5035	2.500-2.501	2.627-2.6285	2.625-2.626	.375	.700	.125
1.875	30	2.627-2.6285	2.625-2.626	2.752-2.7535	2.750-2.751	.375	.700	.125
2.000	32	2.752-2.7535	2.750-2.751	2.877-2.8785	2.875-2.876	.375	.700	.125
2.250	36	3.002-3.0035	3.000-3.001	3.127-3.1285	3.125-3.126	.375	.700	.125
2.500	40	3.375-3.3765	3.372-3.3735	3.4405-3.442	3.4375-3.439	.438	.825	.125
2.750	44	3.626-3.628	3.623-3.6245	3.6905-3.692	3.6875-3.689	.438	.825	.125
3.000	48	3.8795-3.8815	3.876-3.878	3.9405-3.942	3.9375-3.939	.438	.825	.125

* Suggested housing bore diameter is for materials having thermal expansion similar to AISI 416 stainless steel.

Series B-1030

Series B-1035

Series B-1040

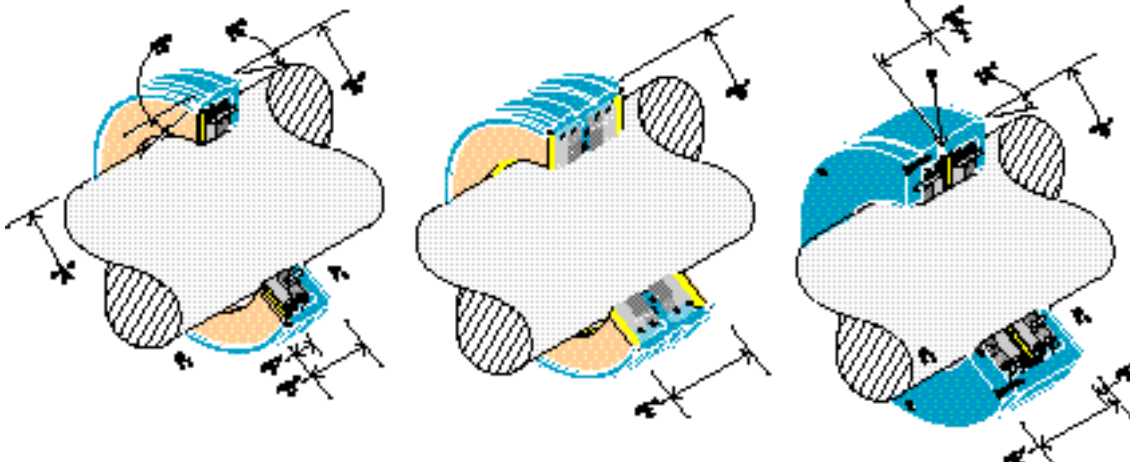

Floating Ring Shaft Seals

The Floating Ring Shaft Seal uses seal rings capable of withstanding high temperatures and high pressures from either direction.

The efficiency of the Floating Ring Shaft Seal depends upon the type of contact between the shaft O.D. and the sealing ring I.D.; therefore, out-of-roundness, surface finish and hardness of the shaft should be

very closely controlled. For maximum sealing efficiency, the surface finish and the hardness of the shaft should be 8 rms maximum and Rc55 minimum, respectively.

Housing and sealing ring materials are selected to eliminate corrosion problems associated with exotic fluids. Typical applications for Floating Ring Shaft

Seals are high temperature control valves and actuators, and atomic control rods. The seal is applicable in reciprocating, oscillating, or in a combination of reciprocating-oscillating uses. One of our applications on a 1/2" shaft sealed 200-psi air at 1000°F. After 40,000 cycles the measured leak rate was .01lbs. per minute.

The Series B-1045 Floating Ring Shaft Seal is used where maximum space savings is required. The Series B-1050 Floating Ring Shaft Seal incorporates a puller groove for ease in removing the seal.

G	H	J	K	L	M	N		
SHAFT O.D. +.0000/-0.0010	SEAL SIZE NO.	SEAL O.D.	HOUSING BORE*	+0.020/-0.000	+/-0.005	+/-0.005	+/-0.005	+/-0.005
0.250	04	.7515-.753	.750-.751	.250	.095	.055	.385	.475
0.375	06	.8765-.878	.875-.876	.250	.095	.055	.510	.600
0.500	08	1.1265-1.128	1.125-1.126	.312	.120	.070	.645	.750
0.625	10	1.2515-1.253	1.250-1.251	.312	.120	.070	.770	.875
0.750	12	1.377-1.3785	1.375-1.376	.312	.120	.070	.895	1.000
0.875	14	1.502-1.5035	1.500-1.501	.312	.120	.070	1.020	1.125
1.000	16	1.627-1.6285	1.625-1.626	.312	.120	.070	1.145	1.250
1.125	18	1.752-1.7535	1.750-1.751	.312	.120	.070	1.270	1.375
1.250	20	1.877-1.8785	1.875-1.876	.312	.120	.070	1.395	1.500
1.375	22	2.002-2.0035	2.000-2.001	.312	.120	.070	1.520	1.625
1.500	24	2.252-2.2535	2.250-2.251	.375	.150	.080	1.675	1.810
1.625	26	2.377-2.3785	2.375-2.376	.375	.150	.080	1.800	1.935
1.750	28	2.502-2.5035	2.500-2.501	.375	.150	.080	1.925	2.060
1.875	30	2.627-2.6285	2.625-2.626	.375	.150	.080	2.050	2.185
2.000	32	2.752-2.7535	2.750-2.751	.375	.150	.080	2.175	2.310
2.250	36	3.002-3.0035	3.000-3.001	.375	.150	.080	2.425	2.560
2.500	40	3.375-3.3765	3.372-3.3735	.438	.180	.090	2.735	2.900
2.750	44	3.626-3.628	3.623-3.6245	.438	.180	.090	2.985	3.150
3.000	48	3.8795-3.8815	3.876-3.878	.438	.180	.090	3.235	3.400

* Suggested housing bore diameter is for materials having thermal expansion similar to AISI 303 stainless steel. Other housing materials and sizes available.

Series B-1045

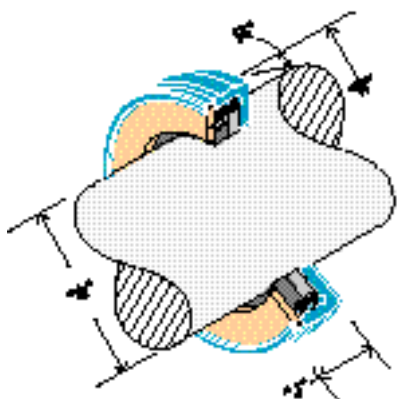

Series B-1050

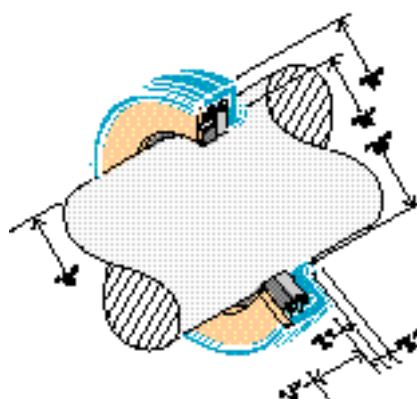

Face Seals

Standard Face seals are of four basic types: Low pressure and high pressure in both normal and extended operating length. Low-pressure face seals will accommodate pressure differences from 0 to 10 psi in either direction; high-pressure seals will accommodate differences from 0 to 500 psi where P_1 is greater than P_2 . The pressure

differential is limited to 0 to 10 psi where P_2 is greater than P_1 . For applications not covered by these ranges, Eaton should be consulted.

These face seals use an elastomeric secondary seal. The elastomeric compounds must be matched to the operating temperature and chemical compatibility requirements of the

sealed media. The upper limit of operating temperatures is taken generally as 400°F. At temperatures above this value, corresponding reductions in operating life can be expected. For higher temperature applications a non-elastomeric secondary seal is available. Please contact Eaton for high temperature or other special requirements.

Mating surfaces for face seals should have a surface hardness of Rc55 minimum with a lapped finish of 4 rms maximum and flatness within 3 helium light bands. A generalization is to hold mating face runout under .001 total indicator reading, since sealing efficiency is directly related to runout.

P		Q		R		S		T		NORMAL OPERATING LENGTH		EXTENDED OPERATING LENGTH		
SHAFT SIZE	SEAL SIZE NO.	MINIMUM SEAL I.D.	SEAL O.D.	FACE HOUSING BORE*	MINIMUM FACE DIAMETER	MAXIMUM FACE DIAMETER	SEAL LENGTH +/- .010	OPERATING WIDTH +/- .010	SEAL LENGTH +/- .010	OPERATING WIDTH +/- .010	U†	V‡	U†	V‡
0.375	06	.400	.813-.815	.811-.8125	.420	.600	.330	.375	-	-	-	-	-	-
0.500	08	.525	1.001-1.003	.999-1.0005	.550	.750	.360	.440	.495	.560	.495	.560	.495	.560
0.625	10	.650	1.126-1.128	1.124-1.1255	.675	.875	.360	.440	.495	.560	.495	.560	.495	.560
0.750	12	.775	1.251-1.253	1.249-1.2505	.800	1.000	.360	.440	.495	.560	.495	.560	.495	.560
0.875	14	0.9	1.438-1.440	1.436-1.4375	.925	1.190	.420	.500	.560	.625	.560	.625	.560	.625
1.000	16	1.025	1.626-1.628	1.62535-1.625	1.050	1.376	.450	.530	.590	.655	.590	.655	.590	.655
1.125	18	1.150	1.751-1.753	1.748-1.750	1.175	1.501	.450	.530	.590	.655	.590	.655	.590	.655
1.250	20	1.275	1.876-1.878	1.873-1.875	1.300	1.626	.450	.530	.590	.655	.590	.655	.590	.655
1.375	22	1.400	2.063-2.065	2.060-2.062	1.425	1.813	.485	.560	.625	.690	.625	.690	.625	.690
1.500	24	1.525	2.188-2.190	2.185-2.187	1.550	1.938	.485	.560	.625	.690	.625	.690	.625	.690
1.625	26	1.655	2.313-2.315	2.310-2.312	1.675	1.973	.485	.560	.625	.690	.625	.690	.625	.690
1.750	28	1.780	2.501-2.503	2.498-2.500	1.800	2.161	.500	.590	.690	.750	.690	.750	.690	.750
1.875	30	1.905	2.626-2.628	2.623-2.625	1.925	2.286	.500	.590	.690	.750	.690	.750	.690	.750
2.000	32	2.030	2.751-2.753	2.748-2.750	2.050	2.411	.500	.590	.690	.750	.690	.750	.690	.750
2.250	36	2.280	3.064-3.066	3.0605-3.0625	2.300	2.724	.640	.750	.865	.940	.865	.940	.865	.940
2.500	40	2.530	3.377-3.379	3.3735-3.3755	2.550	3.037	.700	.810	.895	.970	.895	.970	.895	.970
2.750	44	2.780	3.627-3.629	3.6235-3.6255	2.775	3.287	.700	.810	.895	.970	.895	.970	.895	.970
3.000	48	3.050	3.939-3.941	3.9355-3.9375	3.050	3.599	.720	.875	.985	1.060	.985	1.060	.985	1.060

* Suggested housing bore diameter is for materials having thermal expansion similar to AISI 416 stainless steel.

† Seal extension for normal operating length is .040 inches.

‡ Seal extension for extended operating length is .050 inches.

High Pressure

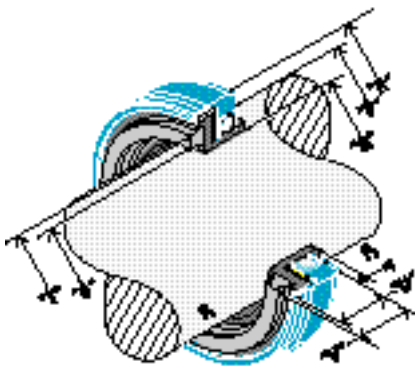

Normal Operating Length – Series B-1060
Extended operating Length – Series B-1062

Low Pressure

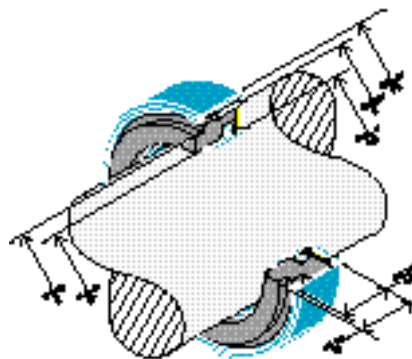

Normal Operating Length – Series 9-1065
Extended Operating Length – Series B-1067

Eaton Corporation
2500 W. Argyle Street
Jackson, MI 49202
USA
tel: (517) 787-8121
fax: (517) 789-4716
email: SealingSystems@Eaton.com
www.aerospace.eaton.com

Eaton Corporation
2 Broad Ground Road Lakeside
Redditch
Worcs B98 8YS
tel: 44 (0) 8105 75-0
fax: 44 (0) 8105 75-55



Aerospace

© 2001 Eaton Corporation
All Rights Reserved
Printed in USA
Form No. APB-51
November 2001