

**Aeroquip®**  
3200 Series Self-Sealing Quick Disconnect

**Request Quote**



[www.herberaircraft.com](http://www.herberaircraft.com)



**EATON**

*Powering Business Worldwide*

# 3200 Series Quick Disconnect

Eaton's Aeroquip® Brand 3200 Series Self-Sealing Coupling is a reliable quick disconnect for 3000 psi (2068.42 kPa) aircraft and missile applications and wherever a fast, safe connection is needed in 3000 psi (2068.42 kPa) hydraulic systems. There is no stable, partially connected position permitting fluid to flow.

3200 Series couplings connect and disconnect with one hand in a single, easy motion. A visual check to verify positive connection is provided by a contrasting color on the locking hex. The positive thread action of the nut provides a mechanical advantage permitting connection against line pressures up to 60 psi (413.68 kPa).

## For Hydraulic Applications

Meets requirements of MIL-C-25427A

For Type II (-65°F to +275°F)  
(-53.88°C to +135°C) systems

## Advantages

- Quick Connecting — easily connects with one hand; disconnects with a straight pull on the union nut.
- Positive Action — valves open simultaneously with the locking action. There is no stable intermediate position where the coupling is partially open and unlocked.
- No Fluid Loss — during connection or disconnection
- Excludes Air, Dirt, Moisture — no cavity to trap air, dirt, or moisture.
- Simple Construction — only thirteen parts plus "O" rings and PTFE back-up rings. No delicate mechanisms to malfunction.

## Principle of Operation

Disconnected Coupling with valves closed. Note how "O" rings provide unexposed and fully protected seal for poppet and tubular valve sleeve.

When connecting, coupling halves align and mate without a cavity, thus preventing air entrapment on connection or fluid spillage on disconnection.

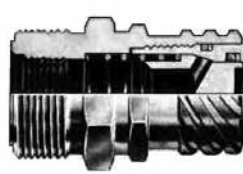

Bulkhead Half

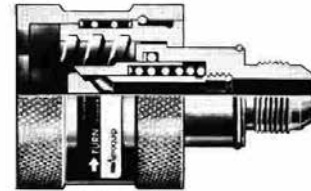

Hose Attaching Half

Fully coupled and locked — valves open. Internal hex in union nut is locked on male body hex. A straight pull of the union nut disengages the lock permitting quick disconnection of the coupling.

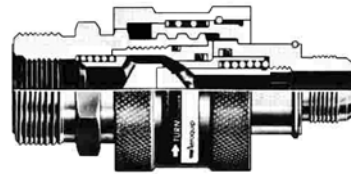

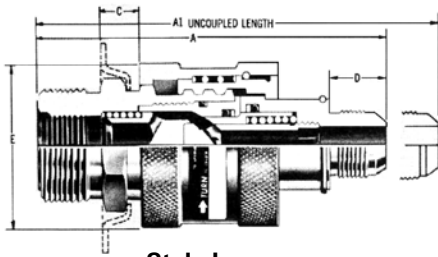

Style I

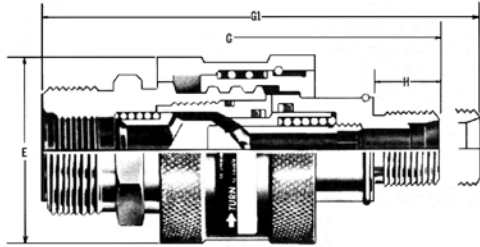

Style II

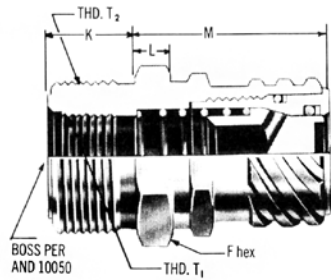

Coupling Half, Hydraulic Bulkhead Mounting

Overall Coupling Lengths – Inches (mm)

Size	– Style –			
	I	II	III	IV
- 4	3.175 (80.645)	3.078 (78.181)	3.729 (94.716)	3.554 (90.271)
- 6	3.566 (90.576)	3.469 (88.112)	4.216 (107.086)	4.018 (102.057)
- 8	3.99 (101.346)	3.893 (98.882)	4.673 (118.694)	4.452 (113.080)
- 10	4.64 (117.855)	4.543 (115.392)	5.41 (137.414)	5.176 (131.470)
- 12	4.919 (124.942)	4.799 (121.894)	5.842 (148.386)	5.507 (139.877)
- 14	5.814 (147.675)	5.715 (145.161)	6.719 (170.662)	6.433 (163.398)

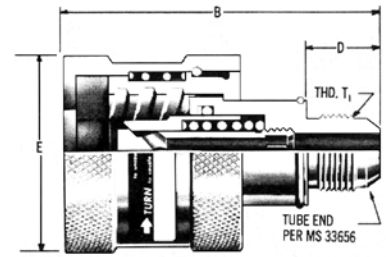

Coupling Half, Hydraulic Hose Attaching

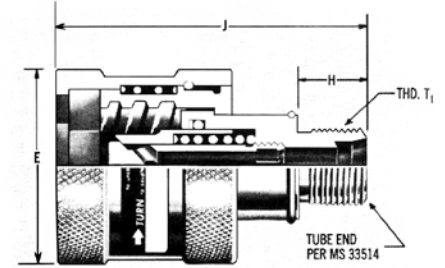

Coupling Half, Hydraulic Hose Attaching

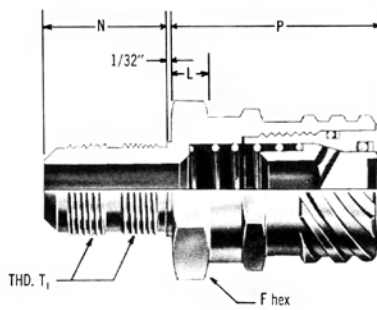

Coupling Half, Hydraulic Bulkhead Mounting

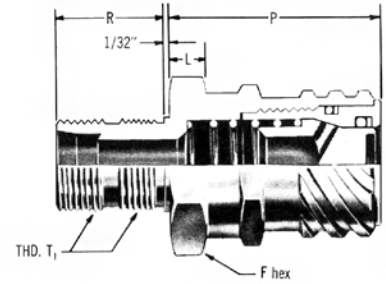

Coupling Half, Hydraulic Bulkhead Mounting

	Dash Size	-4	-6	-8	-10	-12	-16
	Tube Size	1/4"	3/8"	1/2"	5/8"	3/4"	1"
Dimensions inches (mm)	A	3.16 (80.26)	3.57 (90.67)	3.99 (101.34)	4.65 (118.11)	4.93 (125.22)	5.81 (147.57)
	*A1 max	3.77 (95.75)	4.14 (105.15)	4.61 (117.09)	5.34 (135.63)	5.73 (145.54)	6.77 (171.95)
	B	2.16 (54.86)	2.59 (65.78)	2.89 (73.40)	3.38 (85.85)	3.48 (88.39)	4.15 (105.41)
	D	0.55 (13.97)	.556 (14.12)	.657 (16.68)	.758 (19.25)	.864 (21.94)	.911 (23.13)
	E dia. max	1.54 (39.11)	1.67 (42.41)	1.89 (48.00)	2.13 (54.10)	2.38 (60.45)	2.63 (66.80)
	F hex	1.12 (28.448)	1.38 (35.05)	1.62 (41.14)	1.62 (41.14)	1.88 (47.75)	2.12 (53.84)
	G	3.08 (78.23)	3.48 (88.39)	3.89 (98.80)	4.54 (115.31)	4.80 (121.91)	5.72 (145.28)
	*G1 max	3.68 (93.47)	4.06 (103.12)	4.52 (114.80)	5.23 (132.84)	5.58 (141.73)	6.67 (169.41)
	H	0.453 (11.50)	.469 (11.91)	.562 (14.27)	.625 (15.87)	.688 (17.47)	.688 (17.47)
	J	2.07 (52.57)	2.50 (63.5)	2.80 (71.11)	3.27 (83.05)	3.33 (84.58)	4.05 (102.86)
	K	0.594 (15.08)	.594 (15.08)	.718 (18.23)	.781 (19.83)	.906 (23.01)	.938 (23.82)
	L	0.26 (6.60)	.26 (6.60)	.26 (6.60)	.26 (6.60)	.32 (8.12)	.32 (8.12)
	M max	1.28 (32.51)	1.41 (35.81)	1.60 (40.64)	1.84 (46.73)	1.98 (50.29)	2.51 (63.75)
	N	1.016 (25.80)	1.094 (27.78)	1.250 (31.75)	1.391 (35.33)	1.562 (115.87)	1.562 (115.87)
	P max	1.4 (35.56)	1.53 (38.86)	1.72 (43.68)	1.96 (49.78)	2.20 (55.88)	2.78 (70.61)
	R	0.938 (23.82)	.984 (24.99)	1.125 (28.57)	1.266 (32.15)	1.375 (34.92)	1.375 (34.92)
	T1	7/16 -20UNF	9/16 -18UNF	3/4 -16UNF	7/8 -14UNF	1 1/16 -12UN	1 5/16 -12UN
T2	7/8-14UNF	1 1/16 -12UN	1 5/16 -12UN	1 5/16 -12UN	1 5/8 -12UN	1 7/8 -12UN	
Available Weight lbs (kg)	Style I	.281 (0.12)	.425 (0.19)	.638 (0.28)	.897 (0.40)	1.212 (0.54)	1.811 (0.82)
	Style II	.322 (0.14)	.445 (.20)	.649 (0.29)	.908 (0.41)	1.247 (0.56)	1.858 (0.84)
	Style III	.275 (0.12)	.417 (0.18)	.626 (0.28)	.912 (0.41)	1.224 (0.55)	1.901 (0.86)
	Style IV	.274 (0.12)	.414 (0.18)	.613 (0.27)	.902 (0.40)	1.199 (0.54)	1.827 (0.82)
	Style IV	.274 (0.12)	.414 (0.18)	.613 (0.27)	.902 (0.40)	1.199 (0.54)	1.827 (0.82)

# Coupling Styles and Part Numbers

Eaton's Aeroquip 3200 Series Couplings are available for various hydraulic fluids and with all standard end fitting combinations. Select the base part number for coupling halves or coupling assembly from the table below.

Complete the part number by adding dash size to base number (Example: 3200-8). Couplings for other fluids and end fitting styles are available. Contact Eaton for full information.

## Coupling Styles and Part Numbers

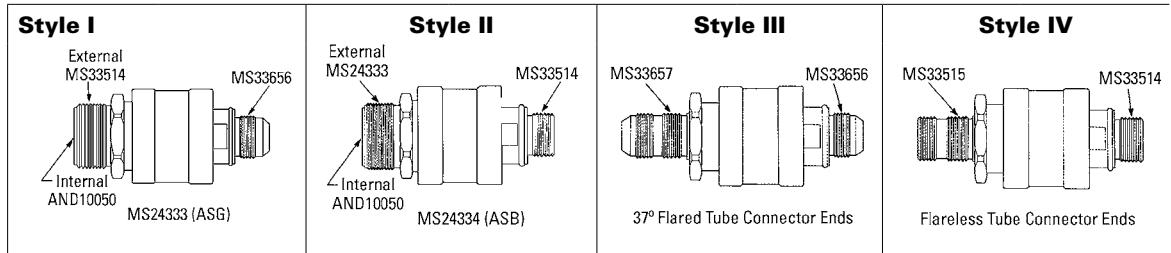

Application	Style I		Style II		Style III		Style IV	
	Hydraulic	Skydrol	Hydraulic	Skydrol	Hydraulic	Skydrol	Hydraulic	Skydrol
<b>Coupling Half, Bulkhead Mounting</b>	3202	320211	3202	320211	3402	340218	3302	330206
<b>Coupling Assembly</b>	3200	320016	320000	N/A	3400	340019	3300	330007
<b>Coupling Half, Hose Attaching</b>	3205	320516	3305	330509	3205	320516	3305	330503

## Optional Mounting Flange and Dust Plugs

Removable, hinged type MS24335 mounting flanges, dust caps, and plugs are available for all sizes.

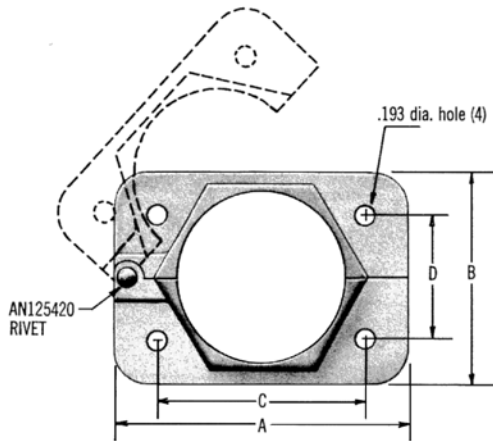

Part Number 3222-size/MS24335-size Mounting Flange

Dash Size	-4	-6	-8	-10	-12	-16
A	2.25 (57.15)	2.5 (63.50)	2.75 (69.85)	2.75 (69.85)	3 (76.19)	3.25 (82.55)
B	1.63 (41.40)	1.81 (45.97)	1.94 (49.27)	2.13 (54.10)	2.38 (60.45)	2.63 (66.80)
C	1.52 (38.60)	1.73 (43.94)	1.95 (49.52)	1.95 (49.52)	2.16 (54.86)	2.38 (60.45)
D	0.88 (22.35)	1 (25.4)	1.13 (28.70)	1.13 (28.70)	1.25 (31.75)	1.38 (35.05)
Wt/lbs (kg)	.043 (0.01)	.051 (0.02)	.063 (0.02)	.070 (0.03)	.074 (0.03)	.102 (0.04)

Material:

1010 Steel, Cadmium Plated (QQ-P-416, Type II Class 2)

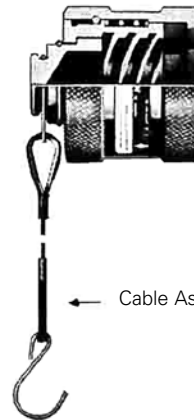

**Dust Cap**  
Part No. 3207-size  
Material: Aluminum

← Cable Assembly

**Dust Plug**  
Part No. 3209-size  
Material: Aluminum

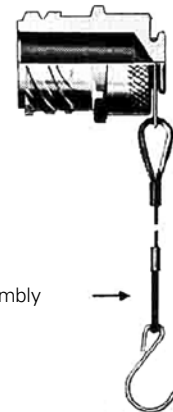

← Cable Assembly

**Pressure Loss Versus Flow**

To find the pressure loss for a given coupling size at a given flow rate —

Find flow rate at bottom of chart and read up until line intersects the curve for the coupling size in question

Read across to find the pressure loss

The coupling may be bulkhead mounted using a jam nut (AN924) or with an optional 4-holed mounting flange (MS24335).

3200 Series couplings are available with end fitting combinations, materials and packings for other fluid applications and for elevated temperature service. 3200 Series part numbers for Skydrol and MIL-H-5606 for Type II systems (-65°F to +275°F) (-53.88°C to +135°C) are listed herein. Contact Eaton for additional information on 3200 Series couplings to meet your specific requirements.

Contact Eaton for ASB-54 Maintenance and Overhaul Manual for 3200 Series Couplings.

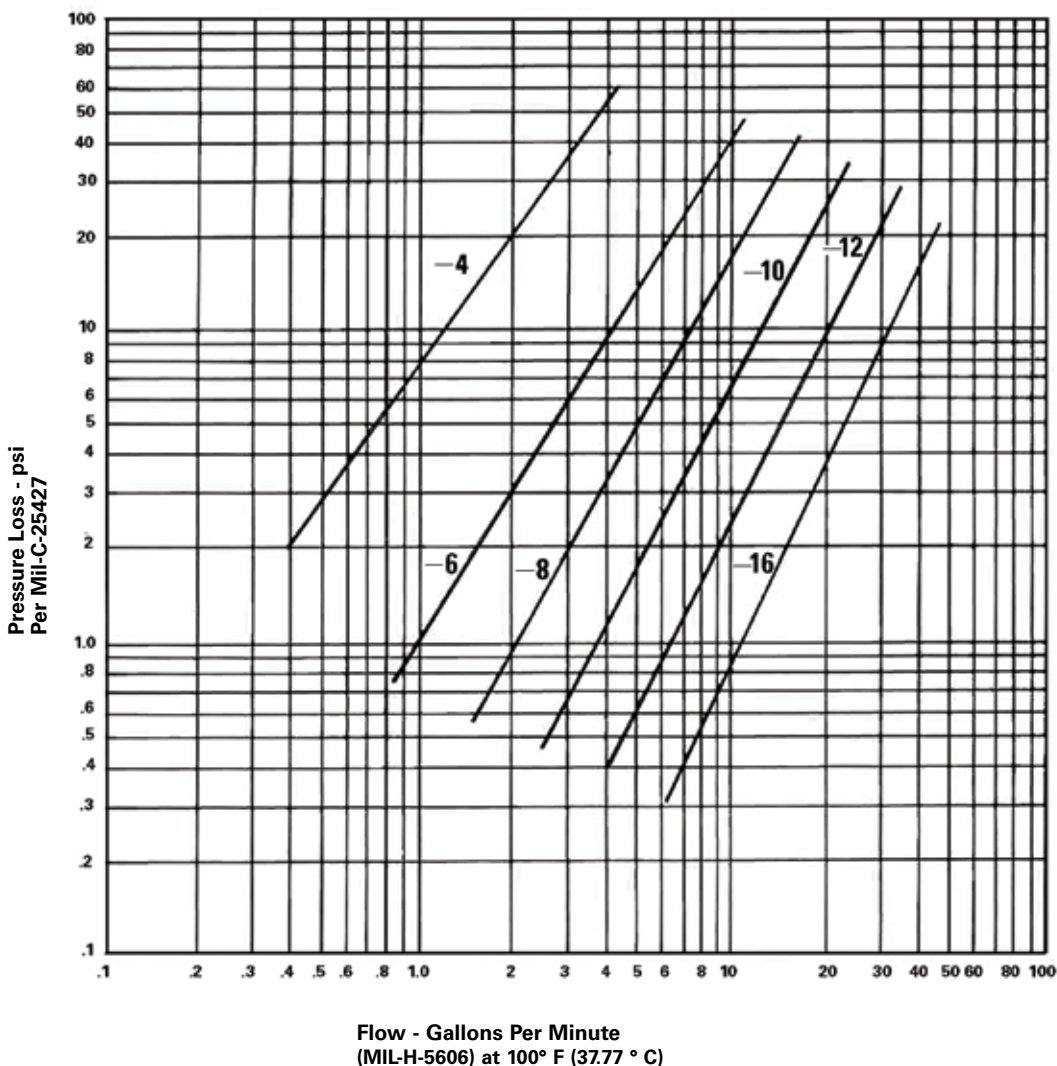

**Eaton**  
**Aerospace Group**  
**Fluid & Electrical Distribution Division**  
**300 South East Avenue**  
**Jackson, Michigan 49203-1972**  
**Phone: (517) 787 8121**  
**Fax: (517) 789 2947**



*Powering Business Worldwide*

Eaton  
Aerospace Group  
9650 Jeronimo Road  
Irvine, California 92618  
Ph (949) 452 9500  
Fax (949) 452 9555  
[www.eaton.com/aerospace](http://www.eaton.com/aerospace)

Copyright © 2018 Eaton  
All Rights Reserved  
Form No. TF100-62C  
October 2018