

Eaton's Aerospace Operations offers an extensive variety of standard catalogs featuring metal seals with numerous cross-sections, sizes and shapes adapted for various customer applications. We are able to offer short lead times on a number of products, all made to order. Our sales, applications and design engineers are all available to work with you to solve your particular leakage problems in a timely, cost-effective manner, often using existing designs adapted to your needs.

As a preferred supplier, partnering supplier or long-term agreement holder with leading original equipment manufacturers worldwide, Eaton meets or exceeds today's strict requirements for the supplier approval process, and commits to long-term, value-added relationships with our customers. Our talented employees are committed to supporting your needs in application assistance, design and value engineering, manufacturing, testing, quality assurance and delivery.

Table of Contents

Introduction

Introduction to Seals and Seal Types	2
Typical Cavities	3
Principles of Metallic Sealing.....	3
Selecting the Correct Seal for Your Application.....	7

C-Seals™

C-Seal Sketch and Description.....	8
Standard Part Number Selection	10
Face Type, Internal Pressure C-Seal Tables	12
Radial C-Seals	15
Face Type, External Pressure C-Seal Tables	16
Boss C-Seals.....	19

E-Seals™

E-Seal Sketch and Description.....	20
Standard Part Number Selection	22
Standard Internal Pressure E-Seal Tables.....	24
Standard External Pressure E-Seal Tables.....	26
High Flex Internal Pressure E-Seal Tables.....	28
High Flex External Pressure E-Seal Tables.....	30
Special 8 E-Seals	32

U-Plex™ Seals

U-Plex Seal Description	42
High-Flex U-Plex Seal Cross Section	43
Standard U-Plex Seal Cross Section Table	44

Microplex Seals

Static Applications	45
---------------------------	----

More Seals

Radial Type Seals	46
More Seal Characteristics, Shapes, and Installation Options	47

Appendix

SI Conversion Factors, Glossary of Terms and Abbreviations.....	48
Instructions for Filling in Drawing Forms	49

Introduction

Introduction to Seals and Seal Types

A seal is a device that prevents the passage, flow or leakage of a gas or fluid. Seals can be divided into two major categories:

1. **Static Seals.** Sealing takes place between surfaces that have little or no movement relative to one another.
2. **Dynamic Seals.** Sealing takes place between surfaces that have relative movement, i.e. the movement of a shaft relative to a housing.

There are also seals that fall between these two categories and do not exactly fit into these basic definitions of static or dynamic seals. Some static seals are designed to accommodate the limited movement of the surfaces being sealed, i.e. due to pressure and/or thermal cycling. These type of seals are sometimes referred to as **resilient, quasi- or semi-static** seals.

Performance of Mechanical Seals

There are many factors that interact and contribute to seal performance. Seal performance factors include seal geometry, contact force, cavity surface finish, sealing medium, pressure differentials and operating temperatures.

Truly static seals aim to provide a complete barrier to a potential leakage path; they are zero-leakage seals (down to 10^{-11} scc/sec. Helium).

To achieve this, the seal must be resilient enough to conform to cavity irregularities and imperfections, while remaining rigid enough to provide the required contact force needed to ensure a tight seal. This contact force is a function of the seal cross-section, as well as the compression of the seal between the mating cavity faces.

Static seals, typically rigid, can be plated or coated with soft plating which, when the seal is installed, will plastically deform into and fill the surface imperfections or asperities (**Figure 1-1**).

Semi-static seals, on the other hand, are not designed or intended to be zero-leakage seals. Their contact or compression force is typically an order of magnitude lower than the static seals. **Table 1-1** gives a typical comparison of load and leakage values for static and semi-static seals.

The actual compression load is a function of the seal cross-section type (C-, E-, U- etc.), material type, heat treatment, material thickness, and the amount of compression or squeeze. These factors affect each type of cross-section differently; some factors have more effect on one section than another.

Static Seals

As previously mentioned, static seals are used between surfaces which have little or no relative cycling (either radially or in the direction, or axis, of compression) once assembled. These seals undergo a high degree of plastic deformation during installation. Once used, static seals should be replaced because of the high plastic or permanent set (i.e. low elastic springback). Exceptions to this may occur when all of the following conditions are met:

1. The measured seal axial height (free height) after operation still exceeds the cavity axial height by a minimum amount (please contact Eaton for guidelines regarding seal reusability).
2. The same seal is to be replaced into its original cavity.
3. Upon reinstallation, the cavity axial height is less than or equal to its original height.

By Eaton's definitions, the C-Seal is the only static seal covered in this catalog.

Semi-Static Seals

All of the remaining seals in this catalog are semi-static (those seals designed to accommodate cavity fluctuations due to thermal, mechanical, dynamic, i.e. vibrations, and/or pressure cycling).

Semi-static seals, as opposed to static seals, are almost always reusable. Designed to operate primarily in the material's elastic range, semi-static seals often exhibit full springback. A few exceptions to this are listed below:

1. Excessive compression.
2. Inadequate or insufficient room for optimum seal cross-section or type, resulting in a stiff section (not flexible enough).
3. Operating temperature extremes resulting in stress relaxation.

Semi-static seals, in particular the E-Seal, U-Plex, and Microplex seals, exhibit compressive loads which are typically an order of magnitude less than those of a static seal. Therefore, platings are not used as a sealing aid since there is insufficient contact loading to plastically deform the platings typically used.

FIGURE 1-1

Purpose of Plating

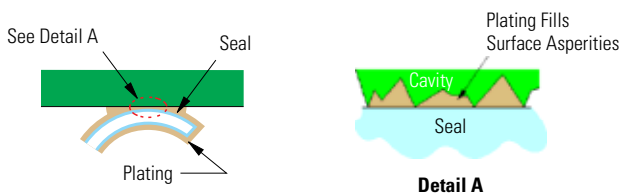

TABLE 1-1

Load and Leakage Values

	Static	Semi-Static
Cross-section	C-Seal	E-Seal, U-Plex, Wave-Sea™ ^{††} , Twist-Flex® ^{††}
Typical Load-to-compress	250-350 lbs./in.Circ.	25-150 lbs./in.Circ.
Typical leakage rate (room temp, 100 psi ΔP)	.005 SCFM/in.Ø to 10 ⁻¹¹ scc/secHe ^{††}	.01 SCFM/in.Ø

[†] Load and leakage values may be higher or lower, respectively, for these sections, since they are radial-type seals.

^{††} Range shown corresponds to unplated and plated seals, respectively; values dependent on surface finish and cross-section selected.

FIGURE 1-2

Standard Closed

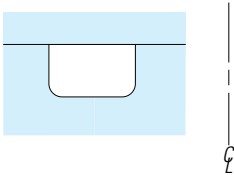

FIGURE 1-3

Standard Open

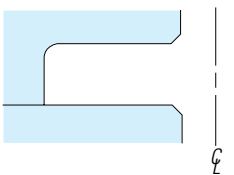

FIGURE 1-4

Corner Cavity

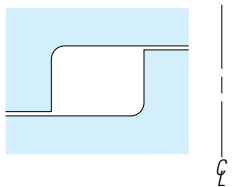
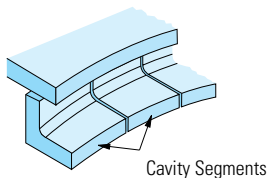

FIGURE 1-5

Segmented Cavity



Typical Cavities

Cavity Type

There are several cavity types that are considered standard. The cavity is a primary design constraint since it determines the physical envelope for the seal's dimensions. The typical standard cavity types are briefly described below and depicted in **Figures 1-2** through **1-5**.

1. **Standard Closed Cavity.** This type of cavity is characterized by a fully enclosed seal area. This type is sometimes referred to as a "U" type cavity. (**Figure 1-2**)
2. **Standard Open Cavity.** This type of cavity is characterized by an open radial dimension. This type is referred to as an "L" type cavity. (**Figure 1-3**)
3. **Corner Cavity.** This type of cavity is often seen in gas turbine engines. (**Figure 1-4**)
4. **Segmented.** This type of cavity is often seen in gas turbine engines at the turbine vane, or nozzle sealing locations. (**Figure 1-5**)

Cavity Dimensions

The following are important cavity design dimensions:

- Minimum Outside Diameter (MIN.O.D.)
- Maximum Inside Diameter (MAX. I.D.)
- Corner Radii (R. MAX. TYP.)

- Corner Edgebreak (CHAMF.)
- Cavity Height (F)

Figure 1-6 shows these dimensions on various cavities.

Principles of Metallic Sealing

I. Eaton's Resilient Metallic Seals—When and Why Used?

Eaton's Metallic Seals are your optimum choice when sealing under any or all of the following conditions:

- A. High Temperatures to Cryogenics—Material Selection
- B. High Pressure
- C. Long Life
- D. Cavity Fluctuations Due to Thermal and/or Pressure Cycling
- E. Need for Extended Shelf Life
- F. Sealing of Corrosive or Hard-to-Handle Gases or Liquids
- G. Need for Cleanliness; Zero Seal Outgassing

A. High Temperatures to Cryogenics—Material Selection

Metallic seals can be used to seal at temperatures outside the recommended operating range of elastomeric seals. Eaton can make a seal from almost any alloy that can be formed. In high-volume applications and when using newly developed alloys, the cost of the alloy is a factor to

consider. Overwhelmingly, however, strength (spring) properties are the primary technical consideration. The more severe the application, the more important it is to use strong, resilient materials. Inconel 718 is Eaton's first choice of material when strength and resiliency are concerns. Inconel 718 offers the best engineering properties for sealing within its operating temperature range.

As for temperature limitations, seal materials offered in this catalog can be used from cryogenics to the elevated temperatures listed in **Table 2**, before the significant effects of stress relaxation and/or oxidation are encountered.

These temperature recommendations correspond to the materials in their fully heat-treated condition; this includes a full solution anneal and precipitation hardening. Please note static-type C-Seals are not recommended for applications above +1200°F (+649°C). At these temperatures, highly stressed material, such as that of a C-Seal when compressed, experiences a phenomenon known as Stress Accelerated Grain Boundary Oxidation Embrittlement (SAGBOE). This is a form of "...stress corrosion cracking, wherein stress and high temperature can result in a rapid diffusion of oxygen down grain boundaries (until the cross-section is sufficiently reduced and results in normal tensile failure). Sensitivity to this

FIGURE 1-6

Cavity Dimensions

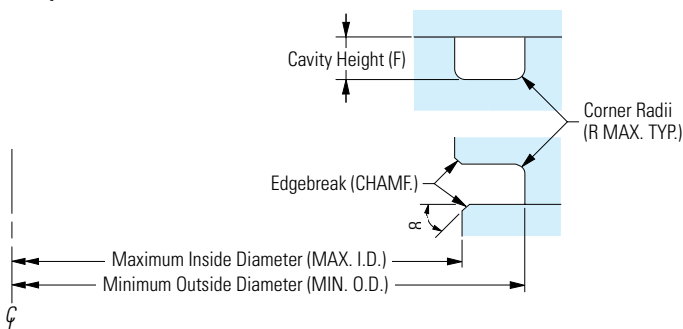

TABLE 2

Temperature Limitations

Seal Material	Seal Type	Max. Recommended Temperature†
Inconel X-750	Static	+1000°F (+538°C)
Inconel 718	All types	+1200°F (+649°C)
Waspaloy	Semi-Static	+1350°F (+732°C)

† This maximum recommended temperature refers to the continuous operating temperature of the seal. Periodic rises from this temperature may be accommodated. Please consult Eaton details.

Introduction

phenomenon depends on many variables, including alloy chemistry, processing history, and final heat treatment."

(This definition is courtesy of an Inco Alloys International Ins. Paper by D.F. Smith entitled Testing Sensitivity in Low CTE Superalloys dated 3/16/91.)

For semi-static seal applications above +1300°F (+704°C), Eaton is researching and developing manufacturing methods for several new high-temperature superalloys. At this time, Eaton successfully utilizes alloys such as Haynes 188® in operating cycles with a maximum temperature of +1600°F (+871°C). Consult Eaton for any applications with operating temperatures greater than +1350°F (+732°C).

B. High Pressure

Eaton's seals are also designed for high-pressure use. C-Seals have operated successfully at pressures above 200,000 psi, and E-Seals have survived pressure pulsations to 8,000 psi without fretting.

Figure 1-7 shows one special feature of the C-Seal: once the seal is compressed, the diameter changes.

This feature enables a clearance fit of the seal in the cavity at installation and a tighter fit between seal and cavity upon compression. This occurs as the seal outer diameter grows, or seal inner diameter shrinks, for an internally pressurized

vs. externally pressurized seal, respectively. The benefit of the tighter fit is better hoop support for a highly pressurized seal.

Although our semi-static seals do not exhibit similar behavior upon compression, it is important to note the I.D. and O.D. support is crucial to maintaining stability and avoiding burst and/or buckling of any cross-section when it is exposed to extreme pressures. This type of support is commonly referred to as back support, as it is the "back" or "closed" portion of the seal which needs support to essentially limit and stop hoop stress from escalating. **Figure 1-8** shows how the seal cavity itself serves as a means of supporting the seal.

C. Long Life Required

In addition to having an infinite shelf life, Eaton's seals, when possible, are designed to have infinite operational life. Exceptions to this would occur with seals operating under excessively extreme conditions, especially related to temperature, wear and vibration. The manufacturing process itself involves a very rigorous test of the material; typical sealing applications are "mild" by comparison. This is especially true of welds. Used at +1300°F (+704°C) and above, Eaton E-Seals have been qualified through 1,100,000 pressure impulse cycles of 400 psi in pneumatic applications.

D. Cavity Fluctuations Due to Thermal and/or Pressure Cycling

Throughout this catalog the emphasis is on the ability of Eaton's semi-static seals to accommodate a cavity's axial and/or radial cycling. These types of cavity movements are shown in **Figure 1-9**.

The material and cross-section selection affect the amount of spring or resiliency of the seal. Once compressed, a semi-static seal will spring back to a given height; sometimes equal to its original height, other times slightly lower. The key, however, is the amount of springback, or return, as depicted in **Figure 1-10**.

E. Need for Extended Shelf Life

Eaton's seals are designed and packaged for infinite shelf life. Generally speaking, our platings also have very extended shelf lives, although some discoloration or plating oxidation may occur after several years. Contact Eaton regarding any questions about the effect of platings on shelf life.

F. Sealing of Corrosive or Hard-to-Handle Gases or Liquids

Eaton's seals are used to seal difficult media including +1200°F (+649°C) air, steam, various oils and lubricants, He, FI, various Freons, HBr, HCl,

HF, N₂O, SiCl₄ and numerous other acids and bases.

G. Need for Cleanliness; No Seal Outgassing

Elastomeric seals typically out-gas water vapor, hydrocarbons, and other particulates which may contaminate the sealed system. Eaton's metallic seals do not create such outgassing problems in your sealed system, and can often be retrofitted into your existing cavity.

II. The PressureScience™ Advantage

- A. Researched and Developed Products
- B. High Quality
- C. Many Cross-Sectional Variations to Fit a Variety of Needs
- D. Weld Tested During Manufacture (Weld Integrity)

A. Researched and Developed Products

Eaton has been designing and manufacturing metallic seals for almost 50 years. We are the originators of the much copied C- and E-Seals and have the longest history of successful experience. Much of the equipment used in the manufacturing of these parts was designed and built by Eaton to meet the specialized needs of these products. Virtually all manufacturing is done in-house including tooling manufacturing,

FIGURE 1-7
Cross-Section Change Due to Compression

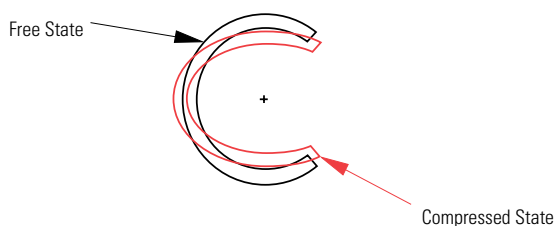
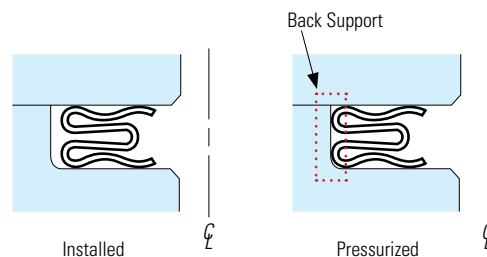

FIGURE 1-8
Back Support



Introduction

welding, metal forming, heat treatment, electroplating and electropolishing. In addition, Eaton performs endurance, proof, burst and other qualification and development tests.

B. High Quality

The PressureScience quality system is capable of meeting the most stringent customer specifications. This is evidenced by the National Aerospace and Defense Contractors Accreditation Program (NADCAP) certifications. NADCAP certification in Chemical Processing, Welding, Heat Treatment and Liquid Penetrant operations assures continued conformance to even the most stringent requirements.

C. Weld Tested in Manufacture (Weld Integrity)

During the entire forming process of Eaton's seals, the weld area is exposed to stress and strain levels significantly higher than those it should ever experience during normal operation. During the remainder of the forming process, the weld area is subjected to severe reverse angulations (semi-static sections) and plastic deformation. Throughout this process, the weld maintains its integrity. Any deformation occurring during operation is negligible compared to that occurring during the forming process; in essence, forming is the most severe test.

D. Many Cross-Sectional Variations to Fit your Needs

In addition to the standard C- and E-Seal cross-sections which have earned Eaton an esteemed reputation and made us the world leader in static metallic seals, we continue to push the limits of design and manufacturability. This is well-demonstrated in other cross-sections featured in this catalog. Throughout this catalog are performance capabilities of some of our most popular types of cross-sections. If you are unable to find a suitable cross-section for your application's needs, manufacture sections not mentioned in this catalog are also available. Many patents have evolved from our expertise in sealing challenging, nonstandard applications. Concurrent engineering philosophies emphasize establishing a team relationship with customers by understanding the customers' sealing requirements and design constraints, Eaton continues to provide innovative sealing solutions.

FIGURE 1-9

Axial and Radial Deflections

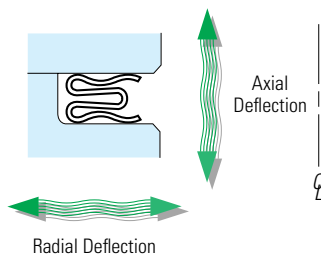
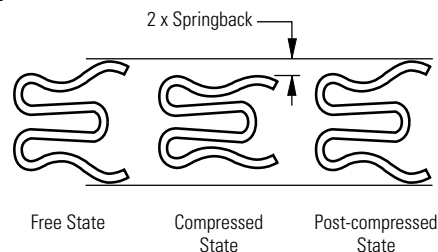
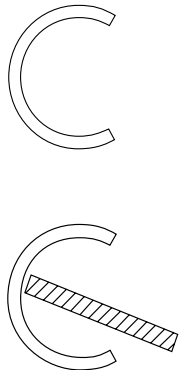
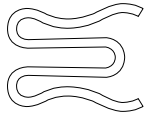
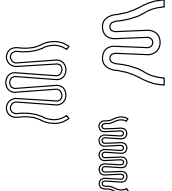
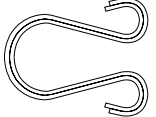

FIGURE 1-10

Springback



Overview of Seals Covered in This Catalog

TYPE OF SEAL	GENERAL COMMENTS AND BASIC FEATURES
<p data-bbox="423 478 609 520">Standard C-Seal and Boss-type C-Seal</p> 	<p data-bbox="763 478 836 504">C-Seal</p> <ul data-bbox="763 514 1404 714" style="list-style-type: none"> • Good for “rigid” connections where little or no axial deflection occurs • Low leakage rates—can be enhanced by plating • Ultra high vacuum (10^{-10} Torr) to high pressure (200,000 psi) applications • Intended to deform plastically; little or no springback • Compression load in the range of 100 to 1000 pounds per circumferential inch of seal (PCI) • See page 9 for more information <p data-bbox="763 735 917 760">Boss-type C-Seal</p> <ul data-bbox="763 770 1356 934" style="list-style-type: none"> • Designed for AS5205 (AS54395) type fittings & A.N.D. 10050 type bosses • Reusable, stays with fitting • Readily “unscrews” from the fitting • Load is not transmitted from the fitting to the boss through the seal • See page 19 for more information
<p data-bbox="423 976 560 1001">Standard E-Seal</p> 	<ul data-bbox="763 976 1307 1113" style="list-style-type: none"> • Flexible, suitable for applications with cyclic axial deflection • Low leakage rates, but higher than C-Seal • Good springback and reusability characteristics • Compression in the range of 10 to 50 PCI • See page 20 for more information
<p data-bbox="423 1144 576 1169">Special 8 E-Seals</p> 	<ul data-bbox="763 1144 1469 1354" style="list-style-type: none"> • Eight most popular designs • Can accommodate a wide range of cavity sizes and movements, beyond the Standard E-Seal • Existing sections, therefore shorter delivery times and at lower cost than custom designs • Build your cavity around your selection, based on operational and performance requirements (pages 33-41) • See page 32 for more information
<p data-bbox="423 1396 527 1421">U-Plex Seal</p> 	<ul data-bbox="763 1396 1388 1522" style="list-style-type: none"> • Extremely flexible • Compression loads 2-3 times lower than the Standard E-Seal • Seal weld distorted flanges as much as 2.5 to 5 times the deformation accommodated by the Standard E-Seal • See page 42 for more information

Introduction

TYPE OF SEAL

GENERAL COMMENTS AND BASIC FEATURES

Microplex Seal

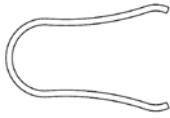

- Flexible, suitable for applications with cyclic axial deflection
- Low leakage, similar to E-seal
- Good springback and reusability characteristics
- Compression in the range of 5 to 50 pci
- Designed for application where the full capabilities of the E-seal are not required
- See page 45 for more information

Radial Type Seals: Wave-Seal (U.S. PAT. NO. 5799954) and Twist-Flex

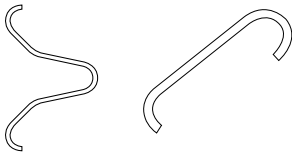

- Offers an interference fit on diameter
- Can serve as a piston ring replacement
- Can accommodate large axial movement by sliding
- Used where no sealing face is available due to cavity geometric and/or load limitations
- See page 46 for more information

Selecting the Correct Seal for Your Application

To determine the type of seal which is best suited for your application, first answer the following questions:

Is the Application Static or Semi-Static?

Static (C-) seals are intended for applications which:

- A. have no axial or radial movement
- B. require tight sealing
- C. can accommodate or require a substantial axial or radial load

If this describes your application, go to the C-Seals section, pages 8-19.

Semi-static seals are intended for applications which:

- A. have some axial and/or radial movement
- B. can accommodate some leakage
- C. require lower axial or radial loads

If this describes your application, go to the Semi-Static section, pages 20-46.

FIGURE 1-11

Static Seal

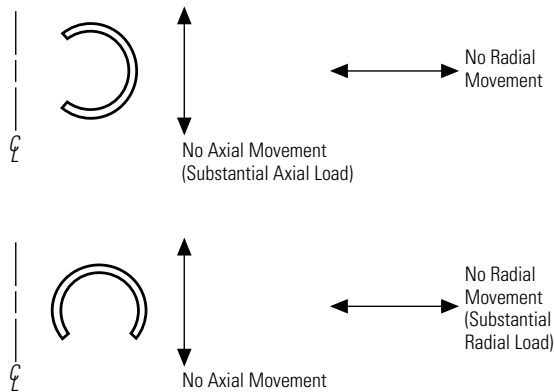
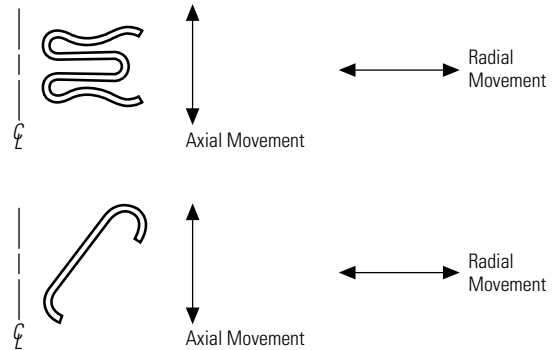
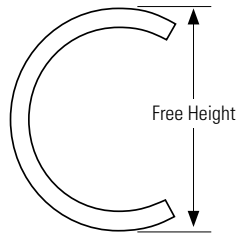

FIGURE 1-12

Semi-Static Seals





C-Seal Sketch and Description

Eaton's C-Seal Performance Capabilities:

- Excellent for "rigid" connections where minimal or no axial deflection occurs
- Low Leakage rates (10^{-11} scc/sec of Helium)
- Ultra high vacuum (10^{-10} Torr) to high pressure (200,000 psi) applications
- Intended to deform plastically; little or no springback
- Compression load in the range of 100 to 1000 PCI

An improvement on the classic metal "O" ring, the C-Seal provides a more flexible, lower load sealing solution which is also pressure energized. Available in three basic orientations (Internal Pressure Face Type, External Pressure Face Type, and Radial Type), the C-Seal offers a simple, inexpensive, and reliable design.

Typical Applications and Locations

- Water Injection Valve—sealing water at 1000 psi, $+600^{\circ}\text{F}$ ($+315^{\circ}\text{C}$)
- Cryogenic Fitting—sealing liquid nitrogen at 1500 psi with zero leakage
- Fuel Injector Seal—sealing fuel at 350 psi, $+1000^{\circ}\text{F}$

($+538^{\circ}\text{C}$), with high exposure to oxygen

- Cryogenic conditions under vacuum, sealing helium
- Toxic or corrosive gases used in laser processing
- Toxic or corrosive gases used in processing and process equipment industries
- Infrared sensing instruments

High-Pressure Capability

To transition from an "O" ring to a "C" shape, the hoop restraint of the seal was greatly reduced. The C-Seal was designed to fit the cavity loosely at installation, but tightly at assembly, or "bolt-up."

Once the closed side of the seal is butted up against the rigid surface of the cavity, the hoop stress is essentially fixed, thus allowing an increase in pressure without an increase in hoop stress through the cross-section. This feature has permitted successful operation of Eaton's C-Seals above 200,000 psi.

Although originally designed for high pressures, C-Seals also work extremely well in lower pressure situations because of their springback and compressive strength characteristics. Additionally, in vacuum environments, the seals tolerate bake-out, and soft platings enable consistent sealing to 10^{-11} scc/sec Helium.

Very Tight Leakage Control

Another feature of the C-Seal, as with all Eaton seals, is the curved or radiused sealing surface.

This radiused sealing surface ensures a circumferential line contact which translates into high unit load on the plating, and thus an effective deformation of the plating into surface irregularities. This line contact offers the best balance with a maximum unit load on the plating with minimum total load on the flanges. Since sealing does not take place on a sharp edge, the problem inherent in plating sharp edges is completely eliminated. Thus, the contact faces are not coined or damaged in use.

Deflection Capability

C-Seals are designed to deform plastically upon a small amount of compression or squeeze. The recommended squeeze on any given C-Seal cross-section is 20%. Once compressed, the C-Seal will deform plastically. However, it will exhibit some springback. Re-use depends on reinstallation conditions. C-Seals may be reusable in their original cavities, or in cavities that are very nearly the same depth as the original. This does not always apply to plated seals in rough (> 63 RMS) cavities. PLEASE CONSULT EATON FOR RE-USE RECOMMENDATIONS.

FIGURE 2-1

Back Support

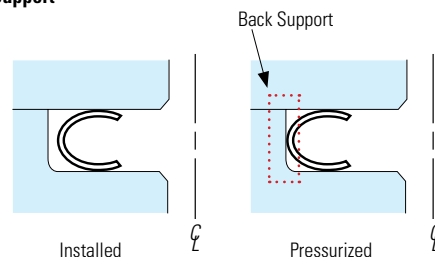
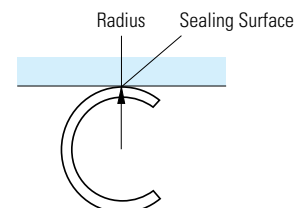

FIGURE 2-2

Curved Sealing Surface



C-Seals

Typical load, deflection, or spring-back capabilities are shown in the Load vs. Deflection graph on page 11. It is not suggested, however, that the C-Seal be utilized in a cavity exhibiting this amount of continuous cavity cycling during operation. As a rule, a C-Seal will springback 2% of its free height. Repeated reinstallations or continuous cavity fluctuations in excess of this amount could result in failure of the seal through cyclic fatigue and cracking.

Standard C-Seal Part Number Selection

The following pages support a simple part number selection process. Make your selection based on the following criteria:

1. Seal Type and Orientation.

Face type, internal or external pressure orientation. Radial type, seal either internal or external pressure, depending on installation orientation.

2. Seal Axial Free Height.

Choose a seal size based on cavity dimensions. The seal material thickness and heat treatment may be varied to attain different load and deflection characteristics. Graphs and scaling factors are provided to assist in the proper selection. Also, if a cavity has not yet been defined, a cross-section based on desired load and deflection characteristics can be selected first, then use the diameter tables to design the cavity.

3. Material Thickness and Heat Treat.

Cross-sections are offered in standard and thinner-than-standard thicknesses for those applications requiring reduced load. As for Heat Treatment options, we recommend full heat-treatment (solution anneal and precipitation hardening). However, NONE may be selected to minimize loadings. Scaling factors for Material Thickness and Heat Treat options are available on page 11.

4. Material Type.

The preferred material of choice for strength and load characteristics is Inconel 718.

5. Plating.

Select a plating based on maximum operating temperature and leakage control requirements, as well as compatibility with media to be sealed. Details on acceptable temperature limitations and leakage comparisons by plating are provided.

6. Diameter Dash Number.

The size of a seal and cavity. Please note, we can also manufacture "in-between" sizes, and larger sizes not included in this catalog. Also, not all sizes referenced are kept in stock. Please consult Eaton to check availability or lead time by calling 301-937-4010.

7. Catalog Code.

Always designated by a "C."

C-Seals

After selecting the part number, expedite your order by filling out a copy of the appropriate drawing form in the Appendix, and faxing to the number on the form. Instructions on filling out the drawing form can be found in the Appendix.

614A91-0036-C

CATALOG CODE

Only option is -C.

DIAMETER DASH NUMBERS

See Tables on pages 12-18 for four-digit diameter designation code.

PLATING

Plating	Plating Thickness, in.		P/N Code		Knoop
	Thin	Thick	Thin	Thick	Hardness
None	—	—	Ø - (only option)		(Reference Only)
Silver, per AMS 2410	.0005 - .0015	.0015 - .0025	1-	X-	40-65
Gold, per MIL-G-45204	.0003 - .0008	.0007 - .0012	2-	Y-	40-75
Nickel, per AMS 2424	.0005 - .002	.0015 - .003	N-	5-	90-100
Lead, per AMS 2414	.001 - .0025	.002 - .004	6-	P-	15 or lower
Tin, per MIL-T-10727	—	—	—	—	6-12
Special Silver, per Eaton spec 0900	.0015 - .0025, Silver (per AMS 2410) PLUS .0003 - .0008, gold (per MIL-G-45204)		F - (Only Option)		39-45

MATERIAL TYPE

Material	Remarks—operating temperature (T)
9: Inconel 718	+1000°F < T ≤ +1200°F† (+538°C < T ≤ +649°C)

† Please consult Eaton for applications above +1200°F (+649°C).

SEAL AXIAL FREE HEIGHT

(Thickness applies to Ø dash numbers greater than 0007.
For dash numbers 0007 and smaller at 1/16" and 3/32" free height, consult factory)

P/N Code	2	3	4	5	6
Free Height	1/16"	3/32"	1/8"	3/16"	1/4"
Standard Thickness	.010"	.015"	.015"	.020"	.025"
Thinner than Standard	.007"	.010"	.010"	.015"	.020"

MATERIAL THICKNESS AND HEAT TREAT

	Code	
	None	Full
A		R
B		S

SEAL TYPE AND ORIENTATION

61: face type, internal pressure

62: radial type

63: face type, external pressure

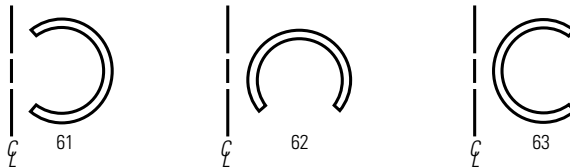

Load (FTC₀) vs. Deflection

FH = Free Height

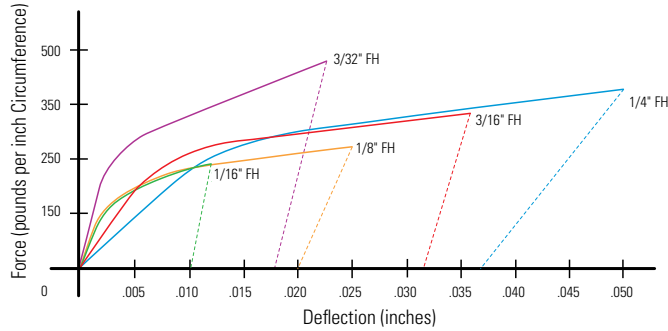

Values based on a seal of 4" mean diameter and fully heat treated 718. Values shown represent face type seals only. Seals were manufactured with standard material thickness and were unplated. For radial-type C-Seal load and deflection characteristics, please consult Eaton.

The following Scaling Factors are to be used as multipliers of the values from the graph to customize seal performance to an application's particular conditions. To obtain approximate force-to-compress (FTC) value, simply multiply the load obtained from the graphs (FTC₀) by the multipliers below that conform to your requirements.

LOAD AND SPRINGBACK SCALING FACTORS

FTC = Force to Compress (your application's specifications)

Heat Treatment

Full: $FTC = FTC_0 \times 1.0$
None: $FTC = FTC_0 \times .07$

Material Thickness

Free Height	Std. Thickness	Thinner than Std.	FTC
1/16"	.010	> .007	= FTC ₀ x 0.43
3/32" - 1/8"	.015	> .010	= FTC ₀ x 0.36
3/16"	.020	> .015	= FTC ₀ x 0.55
1/4"	.025	> .020	= FTC ₀ x 0.67

Plating vs. Temperature Data

Material	Maximum Operating Temperature (°F)	Melting Point (°F)
Indium	312	312
Lead	350	620
Tin	390	449
Special Silver†	1200	1761
Silver	800	1761
Gold	1400	1945
Nickel	1400	2651

†Special Silver contains underlay to prevent oxygen diffusion through silver with consequent attack of bond. Gold flash is used to eliminate blistering in air above +800°F (+427°C).

Plating—Leakage vs. Deflection Data

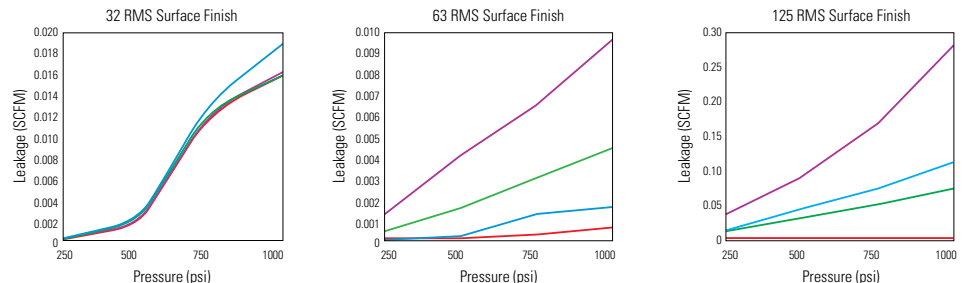

Values based on five 3/32" FH seals, mean diameter of 2" and of fully heat treated X-750. Values shown represent approximate leakage at +1000°F (+538°C).

C-Seals Series 61

FaceType, Internal Pressure C-Seal Tables

DIAMETER DASH NO.	CAVITY I.D. MAX. (E)	SEAL I.D. AVG. MIN. (B)	1/16" FREE HEIGHT		3/32" FREE HEIGHT		1/8" FREE HEIGHT		CAVITY O.D.	SEAL O.D.
			CAVITY O.D. SEAL O.D. AVG. (A)	CAVITY O.D. SEAL O.D. AVG. (A)	CAVITY O.D. SEAL O.D. AVG. (A)	CAVITY O.D. SEAL O.D. AVG. (A)				
			C=	.062 ± .001	.093 ± .001	.125 ± .001	TOLERANCES			
			F=	.050 ± .001	.074 ± .003	.100 ± .003				
			R (MAX.)=	.020	.030	.045				
0002	0.127	0.135	0.250	0.240	***	***	***	***		
0532	0.158	0.166	0.281	0.271	***	***	***	***		
0003	0.200	0.210	0.325	0.315	0.382	0.364	***	***		
0732	0.231	0.241	0.356	0.346	0.413	0.395	***	***		
0004	0.262	0.272	0.387	0.377	0.444	0.426	***	***		
0932	0.294	0.303	0.418	0.408	0.476	0.457	***	***		
0005	0.325	0.335	0.450	0.440	0.507	0.489	***	***		
1132	0.356	0.366	0.481	0.471	0.538	0.520	***	***		
0006	0.387	0.397	0.512	0.502	0.569	0.551	***	***		
1332	0.419	0.428	0.543	0.533	0.600	0.582	***	***	+ 0.001	+ 0.000
0007	0.450	0.460	0.575	0.565	0.632	0.614	***	***	- 0.000	- 0.002
1532	0.481	0.491	0.606	0.596	0.663	0.646	***	***		
0008	0.512	0.522	0.637	0.627	0.694	0.676	***	***		
1732	0.543	0.553	0.668	0.658	0.725	0.707	***	***		
0009	0.575	0.585	0.700	0.690	0.757	0.739	***	***		
1932	0.606	0.616	0.731	0.721	0.788	0.770	***	***		
0010	0.637	0.647	0.762	0.752	0.819	0.801	***	***		
2132	0.669	0.678	0.793	0.783	0.850	0.832	***	***		
0011	0.700	0.710	0.825	0.815	0.882	0.864	***	***		
2332	0.732	0.741	0.856	0.846	0.913	0.895	***	***		
0012	0.763	0.773	0.888	0.878	0.940	0.927	0.990	0.973		
2532	0.795	0.804	0.919	0.909	0.975	0.958	1.021	1.004		
0013	0.826	0.836	0.951	0.941	1.007	0.990	1.053	1.036		
2732	0.857	0.867	0.982	0.972	1.038	1.021	1.084	1.067		
0014	0.888	0.898	1.013	1.003	1.069	1.052	1.115	1.098		
2932	0.920	0.929	1.044	1.034	1.100	1.083	1.146	1.129		
0015	0.951	0.961	1.076	1.066	1.132	1.115	1.178	1.161		
3132	0.982	0.992	1.107	1.097	1.163	1.146	1.209	1.192		
0016	1.013	1.023	1.138	1.128	1.194	1.177	1.240	1.223		
0017	1.045	1.086	1.201	1.191	1.257	1.240	1.305	1.286		
0018	1.107	1.148	1.263	1.253	1.319	1.302	1.365	1.348	+ 0.002	+ 0.000
0019	1.170	1.211	1.326	1.316	1.382	1.365	1.428	1.411	- 0.000	- 0.002
0020	1.232	1.273	1.388	1.378	1.444	1.427	1.490	1.473		
0021	1.295	1.336	1.451	1.441	1.507	1.490	1.551	1.536		
0022	1.357	1.398	1.513	1.503	1.569	1.552	1.615	1.598		
0023	1.420	1.461	1.576	1.566	1.632	1.615	1.678	1.661		
0024	1.482	1.523	1.638	1.628	1.694	1.677	1.740	1.723		
0025	1.545	1.586	1.701	1.691	1.757	1.740	1.805	1.786		
0026	1.607	1.648	1.763	1.753	1.819	1.802	1.865	1.848		
0027	1.670	1.711	1.826	1.816	1.882	1.865	1.928	1.911		
0028	1.732	1.773	1.888	1.878	1.944	1.927	1.990	1.973		
0029	1.795	1.836	1.951	1.941	2.007	1.990	2.051	2.036		
0030	1.857	1.898	2.013	2.003	2.069	2.052	2.115	2.098		
0031	1.920	1.961	2.076	2.066	2.132	2.115	2.178	2.161		
0032	1.999	2.040	2.155	2.145	2.211	2.194	2.257	2.240		
0033	2.061	2.102	2.217	2.207	2.273	2.256	2.319	2.302		
0034	2.124	2.165	2.280	2.270	2.336	2.319	2.382	2.365		
0035	2.186	2.227	2.342	2.332	2.398	2.381	2.444	2.427		
0036	2.249	2.290	2.405	2.395	2.461	2.444	2.507	2.490		
0037	2.311	2.352	2.467	2.457	2.523	2.506	2.569	2.552		
0038	2.374	2.415	2.530	2.520	2.586	2.569	2.632	2.615	+ 0.003	+ 0.000
0039	2.436	2.477	2.592	2.582	2.648	2.631	2.694	2.677	- 0.000	- 0.003
0040	2.499	2.540	2.655	2.645	2.711	2.694	2.757	2.740		
0041	2.561	2.602	2.717	2.707	2.773	2.756	2.819	2.802		
0042	2.624	2.665	2.780	2.770	2.836	2.819	2.882	2.865		
0043	2.686	2.727	2.842	2.832	2.898	2.881	2.944	2.927		
0044	2.749	2.790	2.905	2.895	2.961	2.944	3.007	2.990		
0045	2.811	2.852	2.967	2.957	3.023	3.006	3.069	3.052		
0046	2.874	2.915	3.030	3.020	3.086	3.069	3.132	3.115		
0047	2.936	2.977	3.092	3.082	3.148	3.131	3.194	3.177		
0048	2.999	3.040	3.155	3.145	3.211	3.194	3.257	3.240		
0049	3.061	3.102	3.217	3.207	3.273	3.256	3.319	3.302		
0050	3.124	3.165	3.280	3.270	3.336	3.319	3.382	3.365		
0051	3.186	3.227	3.342	3.332	3.398	3.381	3.444	3.427		
0052	3.249	3.290	3.405	3.395	3.461	3.444	3.507	3.490	+ 0.004	+ 0.000
0053	3.311	3.352	3.467	3.457	3.523	3.506	3.569	3.552	- 0.000	- 0.004
0054	3.374	3.415	3.530	3.520	3.586	3.569	3.632	3.615		
0055	3.436	3.477	3.592	3.582	3.648	3.631	3.694	3.677		
0056	3.491	3.540	3.655	3.645	3.711	3.694	3.757	3.740		

C-Seals Series 61

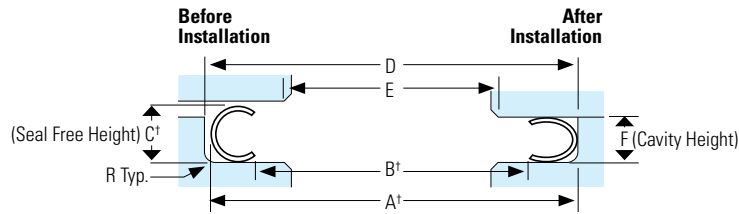

Diagram depicts an open cavity configuration; seals work equally well in a closed cavity configuration with the same envelope dimensions. Seal dimensions are in un-restrained state.
¹Free State

DIAMETER DASH NO.	CAVITY I.D. MAX. (E)	SEAL I.D. AVG. MIN. (B)	1/8" FREE HEIGHT		3/16" FREE HEIGHT		1/4" FREE HEIGHT		CAVITY O.D. (D)	SEAL O.D. (A)	TOLERANCES
			C=	F=	R (MAX.)=	C=	F=	R (MAX.)=			
0057	3.561	3.602	3.819	3.802	3.933	3.902	***	***			
0058	3.624	3.665	3.882	3.865	3.996	3.965	***	***			
0059	3.686	3.727	3.944	3.927	4.058	4.027	***	***			
0060	3.749	3.790	4.007	3.990	4.121	4.090	***	***			
0061	3.811	3.852	4.069	4.052	4.183	4.152	***	***			
0062	3.874	3.915	4.132	4.115	4.246	4.215	***	***			
0063	3.936	3.977	4.194	4.177	4.308	4.277	***	***			
0064	4.024	4.065	4.282	4.265	4.396	4.365	4.510	4.465			
0065	4.086	4.127	4.340	4.327	4.458	4.427	4.572	4.527			
0066	4.149	4.160	4.407	4.390	4.521	4.460	4.653	4.590			
0067	4.211	4.252	4.469	4.452	4.583	4.552	4.697	4.652			
0068	4.274	4.315	4.532	4.515	4.646	4.615	4.760	4.715	+ 0.004	+ 0.000	
0069	4.336	4.377	4.594	4.577	4.708	4.677	4.822	4.777	- 0.000	- 0.008	
0070	4.399	4.440	4.657	4.640	4.771	4.740	4.885	4.840			
0071	4.461	4.502	4.719	4.702	4.833	4.802	4.947	4.902			
0072	4.524	4.565	4.782	4.765	4.896	4.865	5.010	4.965			
0073	4.586	4.627	4.844	4.827	4.958	4.927	5.072	5.027			
0074	4.649	4.690	4.907	4.890	5.021	4.990	5.135	5.090			
0075	4.711	4.752	4.969	4.952	5.083	5.052	5.197	5.152			
0076	4.774	4.815	5.032	5.015	5.146	5.115	5.260	5.215			
0077	4.836	4.877	5.094	5.077	5.208	5.177	5.322	5.277			
0078	4.899	4.940	5.157	5.140	5.271	5.240	5.385	5.340			
0079	4.961	5.002	5.219	5.202	5.333	5.302	5.447	5.402			
0080	5.024	5.065	5.282	5.265	5.396	5.365	5.510	5.465			
0081	5.086	5.115	5.340	5.327	5.458	5.427	5.572	5.527			
0082	5.149	5.178	5.407	5.390	5.521	5.490	5.635	5.590			
0083	5.211	5.240	5.469	5.452	5.583	5.552	5.697	5.652			
0084	5.274	5.303	5.532	5.515	5.646	5.615	5.760	5.715			
0085	5.336	5.365	5.594	5.577	5.708	5.677	5.822	5.777			
0086	5.399	5.428	5.657	5.640	5.771	5.740	5.885	5.840			
0087	5.461	5.490	5.719	5.702	5.833	5.802	5.947	5.902			
0088	5.524	5.553	5.782	5.765	5.896	5.865	6.010	5.965			
0089	5.586	5.615	5.840	5.827	5.958	5.927	6.072	6.027			
0090	5.649	5.678	5.907	5.890	6.021	5.990	6.135	6.090	+ 0.006	+ 0.000	
0092	5.774	5.803	6.032	6.015	6.146	6.115	6.260	6.215	- 0.000	- 0.012	
0094	5.899	5.928	6.157	6.140	6.271	6.240	6.385	6.340			
0096	6.024	6.053	6.282	6.265	6.396	6.365	6.510	6.465			
0098	6.149	6.178	6.407	6.390	6.521	6.490	6.635	6.590			
0100	6.274	6.303	6.532	6.515	6.646	6.615	6.760	6.715			
0102	6.399	6.428	6.657	6.640	6.771	6.740	6.885	6.840			
0104	6.524	6.553	6.782	6.765	6.896	6.865	7.010	6.965			
0106	6.649	6.678	6.907	6.890	7.021	6.990	7.135	7.090			
0108	6.774	6.803	7.032	7.015	7.146	7.115	7.260	7.215			
0110	6.899	6.928	7.157	7.140	7.271	7.240	7.385	7.340			
0112	7.024	7.053	7.282	7.265	7.396	7.365	7.510	7.465			
0114	7.149	7.178	7.407	7.390	7.521	7.490	7.635	7.590			
0116	7.274	7.303	7.532	7.515	7.646	7.615	7.760	7.715			
0118	7.399	7.428	7.657	7.640	7.771	7.740	7.885	7.840			
0120	7.524	7.553	7.782	7.765	7.896	7.865	8.010	7.965			
0122	7.649	7.678	7.907	7.890	8.021	7.990	8.135	8.090			
0124	7.774	7.803	8.032	8.015	8.146	8.115	8.260	8.215			
0126	7.899	7.928	8.157	8.140	8.271	8.240	8.385	8.340			
0128	8.024	8.053	8.282	8.265	8.396	8.365	8.510	8.465			
0130	8.149	8.178	8.407	8.390	8.521	8.490	8.635	8.590			
0132	8.274	8.303	8.532	8.515	8.646	8.615	8.760	8.715			
0134	8.399	8.428	8.657	8.640	8.771	8.740	8.885	8.840			
0136	8.524	8.553	8.782	8.765	8.896	8.865	9.010	8.965			
0138	8.649	8.678	8.907	8.890	9.021	8.990	9.135	9.090			
0140	8.774	8.803	9.032	9.015	9.146	9.115	9.260	9.215	+ 0.008	+ 0.000	
0142	8.899	8.928	9.157	9.140	9.271	9.240	9.385	9.340	- 0.000	- 0.016	
0144	9.024	9.053	9.282	9.265	9.396	9.365	9.510	9.465			
0146	9.149	9.178	9.407	9.390	9.521	9.490	9.635	9.590			
0148	9.274	9.303	9.532	9.515	9.646	9.615	9.760	9.715			
0150	9.399	9.428	9.657	9.640	9.771	9.740	9.885	9.840			
0152	9.524	9.553	9.782	9.765	9.896	9.865	10.010	9.965			
0154	9.649	9.678	9.907	9.890	10.021	9.990	10.135	10.090			
0156	9.774	9.803	10.032	10.015	10.146	10.115	10.260	10.215			
0158	9.899	9.928	10.157	10.140	10.271	10.240	10.385	10.340			
0160	10.024	10.053	10.282	10.265	10.396	10.365	10.510	10.465			

C-Seals Series 61

		1/8" FREE HEIGHT		3/16" FREE HEIGHT		1/4" FREE HEIGHT		TOLERANCES		
		C=	.125 ± .001	.187 ± .002		.250 ± .003				
		F=	.100 ± .003	.151 ± .003		.200 ± .004				
		R (MAX.)=	.045	.070		.090				
DIAMETER DASH NO.	CAVITY I.D. MAX. (E)	SEAL I.D. AVG. MIN. (B)	CAVITY O.D. (D)	SEAL O.D. AVG. (A)	CAVITY O.D. (D)	SEAL O.D. AVG. (A)	CAVITY O.D. (D)	SEAL O.D. AVG. (A)	CAVITY O.D. (D)	SEAL O.D. (A)
0162	10.149	10.170	10.407	10.390	10.521	10.490	10.635	10.590		
0164	10.274	10.295	10.532	10.515	10.646	10.615	10.760	10.715		
0166	10.399	10.420	10.657	10.640	10.771	10.740	10.885	10.840		
0168	10.524	10.545	10.782	10.765	10.896	10.865	11.010	10.965		
0170	10.649	10.670	10.907	10.890	11.021	10.990	11.135	11.090		
0172	10.774	10.795	11.032	11.015	11.146	11.115	11.260	11.215		
0174	10.899	10.920	11.157	11.140	11.271	11.240	11.385	11.340		
0176	11.024	11.045	11.282	11.265	11.396	11.365	11.510	11.465		
0178	11.149	11.170	11.407	11.390	11.521	11.490	11.635	11.590		
0180	11.274	11.295	11.532	11.515	11.646	11.615	11.760	11.715		
0182	11.399	11.420	11.657	11.640	11.771	11.740	11.885	11.840		
0184	11.524	11.545	11.782	11.765	11.896	11.865	12.010	11.965		
0186	11.649	11.670	11.907	11.890	12.021	11.990	12.135	12.090		
0188	11.774	11.795	12.032	12.015	12.146	12.115	12.260	12.215		
0190	11.899	11.920	12.157	12.140	12.271	12.240	12.385	12.340		
0192	12.024	12.045	12.282	12.265	12.396	12.365	12.510	12.465		
0194	12.149	12.170	12.407	12.390	12.521	12.490	12.635	12.590		
0196	12.274	12.295	12.532	12.515	12.646	12.615	12.760	12.715		
0198	12.399	12.420	12.657	12.640	12.771	12.740	12.885	12.840		
0200	12.524	12.545	12.782	12.765	12.896	12.865	13.010	12.965		
0202	12.649	12.670	12.907	12.890	13.021	12.990	13.135	13.090		
0204	12.774	12.795	13.032	13.015	13.146	13.115	13.260	13.215	+ 0.012	+ 0.000
0206	12.899	12.920	13.157	13.140	13.271	13.240	13.385	13.340	- 0.000	- 0.016
0208	13.024	13.045	13.282	13.265	13.396	13.365	13.510	13.465		
0210	13.149	13.170	13.407	13.390	13.521	13.490	13.635	13.590		
0212	13.274	13.295	13.532	13.515	13.646	13.615	13.760	13.715		
0214	13.399	13.420	13.657	13.640	13.771	13.740	13.885	13.840		
0216	13.524	13.545	13.782	13.765	13.896	13.865	14.010	13.965		
0218	13.649	13.670	13.907	13.890	14.021	13.990	14.135	14.090		
0220	13.774	13.795	14.032	14.015	14.146	14.115	14.260	14.215		
0222	13.899	13.920	14.157	14.140	14.271	14.240	14.685	14.340		
0224	14.024	14.045	14.282	14.265	14.396	14.365	14.510	14.465		
0226	14.149	14.170	14.407	14.390	14.521	14.490	14.635	14.590		
0228	14.274	14.295	14.532	14.515	14.646	14.615	14.760	14.715		
0230	14.399	14.420	14.657	14.640	14.771	14.740	14.885	14.840		
0232	14.524	14.545	14.782	14.765	14.896	14.865	15.010	14.965		
0234	14.649	14.670	14.907	14.890	15.021	14.990	15.135	15.090		
0236	14.774	14.795	15.032	15.015	15.146	15.115	15.260	15.215		
0238	14.899	14.920	15.157	15.140	15.271	15.240	15.385	15.340		
0240	15.024	15.045	15.282	15.265	15.396	15.365	15.510	15.465		
0242	15.149	15.160	15.407	15.390	15.521	15.490	15.635	15.590		
0244	15.274	15.285	15.232	15.515	15.646	15.615	15.760	15.715		
0246	15.399	15.410	15.657	15.640	15.771	15.740	15.885	15.840		
0248	15.524	15.550	15.782	15.765	15.896	15.865	16.010	15.965		
0250	15.649	15.660	15.907	15.890	16.021	15.990	16.135	16.090		
0252	15.774	15.785	16.032	16.014	16.146	16.114	16.260	16.214		
0254	15.899	15.910	16.157	16.140	16.271	16.240	16.385	16.340		
0256	16.024	16.035	16.282	16.265	16.396	16.365	16.510	16.465		
0258	16.149	16.160	16.407	16.390	16.521	16.490	16.635	16.590		
0260	16.274	16.285	16.532	16.515	16.646	16.615	16.760	16.715		
0262	16.399	16.410	16.657	16.640	16.771	16.740	16.885	16.840		
0264	16.524	16.535	16.782	16.765	16.896	16.865	17.010	16.965		
0266	16.649	16.660	16.907	16.890	17.021	16.990	17.135	17.090		
0268	16.774	16.785	17.032	17.015	17.146	17.115	17.260	17.215		
0270	16.899	16.910	17.157	17.140	17.271	17.240	17.385	17.340		
0272	17.024	17.035	17.282	17.265	17.396	17.365	17.510	17.465		
0274	17.149	17.160	17.407	17.390	17.521	17.490	17.635	17.590		
0276	17.274	17.285	17.532	17.515	17.646	17.615	17.760	17.715		
0278	17.399	17.410	17.657	17.640	17.771	17.740	17.885	17.840		
0280	17.524	17.535	17.782	17.765	17.896	17.865	18.010	17.965		
0282	17.649	17.660	17.907	17.890	18.021	17.990	18.135	18.090	+ 0.015	+ 0.000
0284	17.774	17.785	18.032	18.015	18.146	18.115	18.260	18.215	- 0.000	- 0.020
0286	17.899	17.910	18.157	18.140	18.271	18.240	18.385	18.340		
0288	18.024	18.035	18.282	18.265	18.396	18.365	18.510	18.465		
0290	18.149	18.160	18.407	18.390	18.521	18.490	18.635	18.590		
0292	18.274	18.285	18.532	18.515	18.646	18.615	18.760	18.715		
0294	18.399	18.410	18.657	18.640	18.771	18.740	18.885	18.840		
0296	18.524	18.535	18.782	18.765	18.896	18.865	19.010	18.965		
0298	18.649	18.660	18.907	18.890	19.021	18.990	19.135	19.090		
0300	18.774	18.785	19.032	19.015	19.146	19.115	19.260	19.215		
0302	18.899	18.910	19.157	19.140	19.271	19.240	19.385	19.340		
0304	19.024	19.035	19.282	19.265	19.396	19.365	19.540	19.465		
0306	19.149	19.160	19.407	19.390	19.521	19.490	19.635	19.590		
0308	19.274	19.285	19.532	19.515	19.646	19.615	19.760	19.715		
0310	19.399	19.410	19.657	19.640	19.771	19.740	19.885	19.840		
0312	19.524	19.535	19.782	19.765	19.896	19.865	20.010	19.965		
0314	19.649	19.660	19.907	19.890	20.021	19.990	20.135	20.090		
0316	19.774	19.785	20.032	20.015	20.146	20.115	20.260	20.215		
0318	19.899	19.910	20.157	20.140	20.271	20.240	20.385	20.340		

C-Seals Series 62

6 2 4 A 5 1 - 0 0 3 6 - C



SEAL AXIAL FREE HEIGHT

P/N Code	2-	3-	4-	5-	6-
Free Height	1/16"	3/32"	1/8"	3/16"	1/4"
Standard Thickness	.010"	.015"	.015"	.020"	.025"
Thinner than Standard	.007"	.010"	.010"	.015"	.020"
Seal Axial Lgth. "G" (Max.)	.058"	.085"	.110"	.160"	.220"
Cavity Axial Lgth. "H" (Min.)	.062"	.093"	.120"	.175"	.240"

Please see page 10 for part number codes except the Free Height and Diameter Dash Number codes which are tabulated below. Inconel X-750 is the recommended material in order to minimize compression loads generated (see Load vs. Deflection graph on page 11 for load information).

[†]Free State

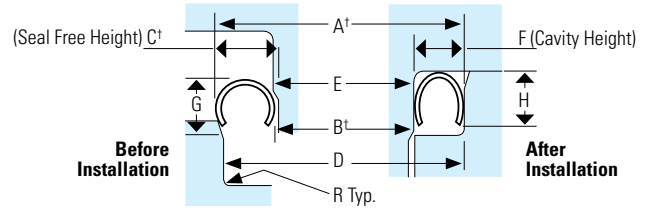

Radial C-Seal Table

DIAMETER DASH NO.	CAVITY I.D. (E)	SEAL I.D. AVG. (B)	CAVITY O.D. (D)	SEAL O.D. AVG. (A)	1/16" FREE HEIGHT (.065)		3/32" FREE HEIGHT (.096)		1/8" FREE HEIGHT (.127)		TOLERANCES
					CAVITY O.D. (D)	SEAL O.D. AVG. (A)	CAVITY O.D. (D)	SEAL O.D. AVG. (A)	CAVITY O.D. (D)	SEAL O.D. AVG. (A)	
0004	0.250	0.247	0.373	0.376	***	***	***	***	***	***	↑
0005	0.312	0.309	0.435	0.438	0.498	0.501	0.560	0.563	0.623	0.626	
0006	0.375	0.372	0.498	0.501	0.560	0.563	0.623	0.626	0.685	0.688	
0007	0.437	0.434	0.560	0.563	0.623	0.626	0.685	0.688	0.748	0.751	
0008	0.500	0.497	0.623	0.626	0.685	0.688	0.748	0.751	0.810	0.813	
0009	0.562	0.559	0.685	0.688	0.748	0.751	0.810	0.813	0.873	0.876	
0010	0.625	0.622	0.748	0.751	0.810	0.813	0.873	0.876	0.935	0.938	
0011	0.687	0.684	0.810	0.813	0.873	0.876	0.935	0.938	0.998	1.001	
0012	0.750	0.747	0.873	0.876	0.935	0.938	0.998	1.001	1.060	1.063	
0013	0.812	0.809	0.935	0.938	0.998	1.001	1.060	1.063	1.123	1.126	
0014	0.875	0.872	0.998	1.001	1.060	1.063	1.123	1.126	1.185	1.188	
0015	0.937	0.934	1.060	1.063	1.123	1.126	1.185	1.188	1.248	1.251	
0016	1.000	0.997	1.123	1.126	1.185	1.188	1.248	1.251	1.310	1.313	
0018	1.125	1.122	1.248	1.251	1.310	1.313	1.370	1.376	1.435	1.438	
0020	1.250	1.247	1.373	1.376	1.435	1.438	1.498	1.501	1.560	1.563	
0022	1.375	1.372	1.498	1.501	1.560	1.563	1.623	1.626	1.685	1.688	
0024	1.500	1.497	***	***	1.685	1.688	1.748	1.751	1.810	1.813	
0026	1.625	1.622	***	***	1.810	1.813	1.873	1.876	1.935	1.938	
0028	1.750	1.747	***	***	1.935	1.938	1.998	2.001	2.060	2.063	
0030	1.875	1.872	***	***	2.060	2.063	2.123	2.126	2.185	2.188	
0032	2.000	1.997	***	***	2.185	2.188	2.248	2.251	2.310	2.313	
0034	2.125	2.122	***	***	2.310	2.313	2.373	2.376	2.435	2.438	
0036	2.250	2.247	***	***	2.435	2.438	2.498	2.501	2.560	2.563	
0038	2.375	2.372	***	***	2.560	2.563	2.623	2.626	2.685	2.688	
0040	2.500	2.497	***	***	2.685	2.688	2.748	2.751	2.810	2.813	
0042	2.625	2.622	***	***	2.810	2.813	2.873	2.876	2.935	2.938	
0044	2.750	2.747	3/16" FH (C=.190)	2.935	2.938	2.998	3.001	3.060	3.063	3.123	
0046	2.875	2.872	Cavity O.D. Seal O.D.	3.060	3.063	3.123	3.126	3.185	3.188	3.248	
0048	3.000	2.995	3.369	3.374	3.435	3.438	3.498	3.501	3.560	3.563	
0050	3.125	3.120	3.494	3.499	3.560	3.563	3.623	3.626	3.685	3.688	
0052	3.250	3.245	3.619	3.624	3.685	3.688	3.748	3.751	3.810	3.813	
0054	3.375	3.370	3.744	3.749	3.810	3.813	3.873	3.876	3.935	3.938	
0056	3.500	3.495	3.869	3.874	3.935	3.938	4.000	4.003	4.060	4.063	
0058	3.625	3.620	3.994	3.999	4.060	4.063	4.123	4.126	4.185	4.188	
0060	3.750	3.745	4.119	4.124	4.185	4.188	4.248	4.251	4.310	4.313	
0062	3.875	3.870	4.244	4.249	4.310	4.313	4.373	4.376	4.435	4.438	
0064	4.000	3.995	4.369	4.374	4.435	4.438	4.498	4.501	4.560	4.563	
0066	4.125	4.120	4.494	4.499	4.560	4.563	4.623	4.626	4.685	4.688	
0068	4.250	4.245	4.619	4.624	4.685	4.688	4.748	4.751	4.810	4.813	
0070	4.375	4.370	4.744	4.749	4.810	4.813	4.873	4.876	4.935	4.938	
0072	4.500	4.495	4.869	4.874	4.935	4.938	5.000	5.003	5.060	5.063	
0074	4.625	4.620	4.994	4.999	5.060	5.063	5.123	5.126	5.185	5.188	
0076	4.750	4.745	5.119	5.124	5.185	5.188	5.248	5.251	5.310	5.313	
0078	4.875	4.870	5.244	5.249	5.310	5.313	5.373	5.376	5.435	5.438	
0080	5.000	4.995	5.369	5.374	5.435	5.438	5.498	5.501	5.560	5.563	
0082	5.125	5.120	5.494	5.499	5.560	5.563	5.623	5.626	5.685	5.688	
0084	5.250	5.245	5.619	5.624	5.685	5.688	5.748	5.751	5.810	5.813	
0086	5.375	5.370	5.744	5.749	5.810	5.813	5.873	5.876	5.935	5.938	
0088	5.500	5.495	5.869	5.874	5.935	5.938	6.000	6.003	6.060	6.063	

C-Seals Series 63

Face Type, External Pressure C-Seal Tables

DIAMETER DASH NO.	CAVITY I.D. (E)	SEAL I.D. AVG. (B)	1/16" FREE HEIGHT		3/32" FREE HEIGHT		1/8" FREE HEIGHT		TOLERANCES	SEAL I.D. (B)
			CAVITY O.D. MIN. (D)	SEAL O.D. AVG. MAX. (A)	CAVITY O.D. MIN. (D)	SEAL O.D. AVG. MAX. (A)	CAVITY O.D. MIN. (D)	SEAL O.D. AVG. MAX. (A)		
			C=	.062 ± .001		.093 ± .001		.125 ± .001		
			F=	.050 ± .001		.074 ± .003		.100 ± .003		
			R MAX.=	.020		.030		.045		
0002	0.108	0.128	0.244	0.233	***	***	***	***		
0532	0.139	0.159	0.275	0.264	***	***	***	***		
0003	0.171	0.191	0.307	0.296	0.366	0.351	***	***		
0732	0.201	0.221	0.338	0.327	0.397	0.381	***	***		
0004	0.232	0.252	0.369	0.358	0.428	0.412	***	***		
0932	0.263	0.283	0.400	0.389	0.459	0.443	***	***		
0005	0.295	0.315	0.432	0.421	0.491	0.475	***	***		
1132	0.326	0.346	0.463	0.452	0.522	0.506	***	***		
0006	0.357	0.377	0.494	0.483	0.553	0.537	***	***		
1332	0.391	0.408	0.525	0.514	0.584	0.568	***	***		
0007	0.420	0.440	0.557	0.546	0.616	0.600	***	***	+ 0.000 - 0.001	+ 0.002 - 0.000
1532	0.451	0.471	0.588	0.577	0.647	0.631	***	***		
0008	0.482	0.502	0.619	0.608	0.678	0.662	***	***		
1732	0.513	0.533	0.650	0.639	0.709	0.693	***	***		
0009	0.545	0.565	0.682	0.671	0.741	0.725	***	***		
1932	0.576	0.596	0.713	0.702	0.772	0.756	***	***		
0010	0.607	0.627	0.744	0.733	0.803	0.787	***	***		
2132	0.638	0.658	0.775	0.764	0.834	0.818	***	***		
0011	0.669	0.689	0.807	0.796	0.866	0.849	***	***		
2332	0.701	0.721	0.838	0.827	0.897	0.881	***	***		
0012	0.732	0.752	0.869	0.848	0.928	0.912	0.987	0.953		
2532	0.763	0.783	0.900	0.889	0.959	0.943	1.018	0.984		
0013	0.795	0.815	0.932	0.921	0.991	0.975	1.050	1.016		
2732	0.826	0.846	0.963	0.952	1.022	1.006	1.081	1.047		
0014	0.857	0.877	0.994	0.983	1.053	1.037	1.112	1.078		
2932	0.888	0.908	1.025	1.014	1.084	1.068	1.143	1.104		
0015	0.920	0.940	1.057	1.046	1.116	1.100	1.175	1.141		
3132	0.951	0.971	1.088	1.077	1.147	1.131	1.203	1.172		
0016	0.982	1.002	1.119	1.108	1.178	1.162	1.237	1.203		
0017	1.045	1.065	1.182	1.171	1.241	1.225	1.300	1.266		
0018	1.107	1.127	1.244	1.233	1.303	1.287	1.362	1.328	+ 0.000 - 0.002	+ 0.002 - 0.000
0019	1.171	1.191	1.307	1.296	1.366	1.351	1.426	1.392		
0020	1.232	1.252	1.369	1.358	1.428	1.412	1.487	1.453		
0021	1.295	1.315	1.432	1.421	1.491	1.475	1.550	1.516		
0022	1.357	1.377	1.494	1.483	1.553	1.537	1.612	1.578		
0023	1.420	1.440	1.557	1.546	1.616	1.600	1.675	1.641		
0024	1.482	1.502	1.619	1.608	1.678	1.662	1.737	1.703		
0025	1.545	1.565	1.682	1.671	1.741	1.725	1.800	1.766		
0026	1.607	1.627	1.744	1.733	1.803	1.787	1.862	1.828		
0027	1.670	1.690	1.807	1.796	1.866	1.850	1.925	1.891		
0028	1.732	1.752	1.869	1.858	1.928	1.912	1.987	1.953		
0029	1.795	1.815	1.932	1.921	1.991	1.975	2.050	2.016		
0030	1.857	1.877	1.994	1.983	2.053	2.037	2.112	2.078		
0031	1.920	1.940	2.057	2.046	2.116	2.100	2.175	2.141		
0032	1.983	2.003	2.119	2.108	2.178	2.163	2.237	2.203		
0033	2.042	2.066	2.182	2.171	2.241	2.226	2.300	2.266		
0034	2.104	2.128	2.244	2.233	2.303	2.288	2.362	2.328		
0035	2.167	2.191	2.307	2.296	2.366	2.351	2.425	2.391		
0036	2.229	2.253	2.369	2.358	2.428	2.413	2.487	2.453		
0037	2.291	2.315	2.432	2.421	2.491	2.476	2.550	2.515		
0038	2.354	2.378	2.494	2.483	2.553	2.538	2.612	2.578	+ 0.000 - 0.003	+ 0.003 - 0.000
0039	2.417	2.441	2.557	2.546	2.616	2.601	2.675	2.641		
0040	2.479	2.503	2.619	2.608	2.678	2.663	2.737	2.703		
0041	2.542	2.566	2.682	2.671	2.741	2.726	2.800	2.766		
0042	2.604	2.628	2.744	2.733	2.803	2.788	2.862	2.828		
0043	2.667	2.691	2.807	2.796	2.866	2.851	2.925	2.891		
0044	2.728	2.753	2.869	2.858	2.928	2.913	2.987	2.953		
0045	2.778	2.816	2.932	2.921	2.991	2.976	3.050	3.016		
0046	2.854	2.878	2.994	2.983	3.053	3.038	3.112	3.078		
0047	2.917	2.941	3.057	3.046	3.116	3.101	3.175	3.141		
0048	2.979	3.003	3.119	3.108	3.178	3.163	3.237	3.203		
0049	3.042	3.066	3.182	3.171	3.241	3.226	3.300	3.266		
0050	3.104	3.128	3.244	3.233	3.303	3.288	3.362	3.328		
0051	3.167	3.191	3.307	3.296	3.366	3.351	3.425	3.391		
0052	3.229	3.253	3.369	3.358	3.428	3.413	3.487	3.453	+ 0.000 - 0.004	+ 0.004 - 0.000
0053	3.292	3.316	3.432	3.421	3.491	3.476	3.550	3.516		
0054	3.354	3.378	3.494	3.483	3.553	3.538	3.612	3.578		
0055	3.417	3.441	3.557	3.546	3.616	3.601	3.675	3.641		
0056	3.479	3.503	3.619	3.608	3.678	3.663	3.737	3.703		

C-Seals Series 63

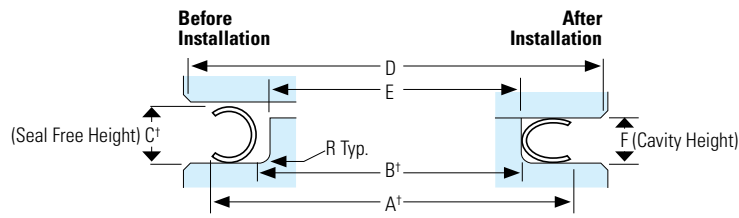

DIAMETER DASH NO.	CAVITY I.D. (E)	SEAL I.D. AVG. (B)	1/8" FREE HEIGHT		3/16" FREE HEIGHT		1/4" FREE HEIGHT		CAVITY I.D. (E)	SEAL I.D. (B)
			C= F= R MAX.=	.125 ± .001 .100 ± .003 .045	.187 ± .002 .151 ± .003 .070	.250 ± .003 .200 ± .004 .090	TOLERANCES			
0057	3.533	3.566	3.800	3.766	3.919	3.867	***	***		
0058	3.595	3.628	3.862	3.828	3.981	3.929	***	***		
0059	3.658	3.691	3.925	3.891	4.044	3.992	***	***		
0060	3.720	3.753	3.987	3.953	4.106	4.054	***	***		
0061	3.783	3.816	4.050	4.016	4.169	4.117	***	***		
0062	3.845	3.878	4.112	4.078	4.231	4.179	***	***		
0063	3.908	3.941	4.175	4.141	4.294	4.242	***	***		
0064	3.970	4.003	4.237	4.203	4.356	4.304	4.475	4.405		
0065	4.029	4.066	4.300	4.266	4.419	4.367	4.538	4.468		
0066	4.091	4.128	4.362	4.328	4.481	4.429	4.600	4.530		
0067	4.154	4.191	4.425	4.391	4.544	4.492	4.663	4.593		
0068	4.216	4.253	4.487	4.453	4.606	4.554	4.725	4.655	+ 0.000	+ 0.004
0069	4.279	4.316	4.550	4.516	4.669	4.617	4.788	4.718	- 0.004	- 0.000
0070	4.341	4.378	4.612	4.578	4.731	4.679	4.850	4.780		
0071	4.404	4.441	4.675	4.641	4.764	4.742	4.913	4.843		
0072	4.466	4.503	4.737	4.703	4.856	4.804	4.975	4.905		
0073	4.529	4.566	4.800	4.766	4.919	4.867	5.038	4.968		
0074	4.591	4.628	4.862	4.828	4.981	4.929	5.100	5.030		
0075	4.654	4.691	4.925	4.891	5.044	4.992	5.163	5.093		
0076	4.716	4.753	4.987	4.953	5.106	5.054	5.225	5.155		
0077	4.779	4.816	5.050	5.016	5.169	5.117	5.288	5.218		
0078	4.841	4.878	5.112	5.078	5.231	5.179	5.350	5.280		
0079	4.904	4.941	5.175	5.141	5.294	5.242	5.413	5.343		
0080	4.966	5.003	5.237	5.203	5.356	5.304	5.475	5.405		
0081	5.029	5.066	5.300	5.278	5.419	5.378	5.538	5.478		
0082	5.091	5.128	5.362	5.340	5.481	5.440	5.600	5.540		
0083	5.154	5.191	5.425	5.403	5.544	5.503	5.663	5.603		
0084	5.216	5.253	5.487	5.465	5.606	5.565	5.725	5.665		
0085	5.279	5.316	5.550	5.528	5.669	5.628	5.788	5.728		
0086	5.341	5.378	5.612	5.590	5.731	5.690	5.850	5.790		
0087	5.404	5.441	5.675	5.653	5.794	5.753	5.913	5.853		
0088	5.466	5.503	5.737	5.715	5.856	5.815	5.975	5.915		
0089	5.529	5.566	5.800	5.778	5.919	5.878	6.038	5.978		
0090	5.591	5.628	5.862	5.840	5.981	5.940	6.100	6.040	+ 0.000	+ 0.012
0092	5.716	5.753	5.987	5.965	6.106	6.065	6.225	6.165	- 0.006	- 0.000
0094	5.841	5.878	6.112	6.090	6.231	6.190	6.350	6.290		
0096	5.966	6.003	6.237	6.215	6.356	6.315	6.475	6.415		
0098	6.091	6.128	6.362	6.340	6.481	6.440	6.600	6.540		
0100	6.216	6.253	6.487	6.465	6.606	6.565	6.725	6.665		
0102	6.341	6.378	6.612	6.590	6.731	6.690	6.850	6.790		
0104	6.466	6.503	6.737	6.715	6.856	6.815	6.975	6.915		
0106	6.591	6.628	6.862	6.840	6.981	6.940	7.100	7.040		
0108	6.716	6.753	6.987	6.965	7.106	7.065	7.225	7.165		
0110	6.841	6.878	7.112	7.090	7.231	7.190	7.350	7.290		
0112	6.966	7.003	7.237	7.215	7.356	7.315	7.475	7.415		
0114	7.091	7.128	7.362	7.343	7.481	7.443	7.600	7.543		
0116	7.216	7.253	7.487	7.468	7.606	7.568	7.725	7.668		
0118	7.341	7.378	7.612	7.593	7.731	7.693	7.850	7.793		
0120	7.466	7.503	7.737	7.718	7.856	7.818	7.975	7.918		
0122	7.591	7.628	7.862	7.843	7.981	7.943	8.100	8.043		
0124	7.716	7.753	7.987	7.968	8.106	8.068	8.225	8.168		
0126	7.841	7.878	8.112	8.093	8.231	8.193	8.350	8.293		
0128	7.966	8.003	8.237	8.218	8.356	8.318	8.475	8.418		
0130	8.091	8.128	8.362	8.343	8.481	8.443	8.600	8.543		
0132	8.216	8.253	8.487	8.468	8.606	8.568	8.725	8.668		
0134	8.341	8.378	8.612	8.593	8.731	8.693	8.850	8.793		
0136	8.466	8.503	8.737	8.718	8.856	8.818	8.975	8.918	+ 0.000	+ 0.016
0138	8.591	8.628	8.862	8.843	8.981	8.943	9.100	9.043	- 0.008	- 0.000
0140	8.716	8.753	8.987	8.968	9.106	9.068	9.225	9.168		
0142	8.841	8.878	9.112	9.093	9.231	9.193	9.350	9.293		
0144	8.966	9.003	9.237	9.218	9.356	9.318	9.475	9.418		
0146	9.091	9.128	9.362	9.343	9.481	9.443	9.600	9.543		
0148	9.216	9.253	9.487	9.468	9.606	9.568	9.725	9.668		
0150	9.341	9.378	9.612	9.593	9.731	9.693	9.850	9.793		
0152	9.466	9.503	9.737	9.718	9.856	9.818	9.975	9.918		
0154	9.591	9.628	9.862	9.843	9.981	9.943	10.100	10.043		
0156	9.716	9.753	9.987	9.968	10.106	10.068	10.225	10.168		
0158	9.841	9.878	10.112	10.093	10.231	10.193	10.350	10.293		
0160	9.966	10.003	10.237	10.218	10.356	10.318	10.475	10.418		

C-Seals Series 63

		1/8" FREE HEIGHT		3/16" FREE HEIGHT		1/4" FREE HEIGHT		TOLERANCES		
C=		.125 ± .001		.187 ± .002		.250 ± .003				
F=		.100 ± .003		.074 ± .003		.200 ± .004				
R MAX.=		.045		.070		.090				
DIAMETER DASH NO.	CAVITY I.D. (E)	SEAL I.D. AVG. (B)	CAVITY O.D. MIN. (D)	SEAL O.D. AVG. MAX. (A)	CAVITY O.D. MIN. (D)	SEAL O.D. AVG. MAX. (A)	CAVITY O.D. MIN. (D)	SEAL O.D. AVG. MAX. (A)	CAVITY I.D. (E)	SEAL I.D. (B)
0162	10.091	10.128	10.362	10.348	10.481	10.448	10.600	10.548		
0164	10.216	10.253	10.487	10.473	10.606	10.573	10.725	10.673		
0166	10.341	10.378	10.612	10.598	10.731	10.698	10.850	10.798		
0168	10.466	10.503	10.737	10.723	10.856	10.823	10.975	10.923		
0170	10.591	10.628	10.862	10.848	10.981	10.948	11.100	11.048		
0172	10.716	10.753	10.987	10.973	11.106	11.073	11.225	11.173		
0174	10.841	10.878	11.112	11.098	11.231	11.198	11.350	11.298		
0176	10.966	11.003	11.237	11.223	11.356	11.323	11.475	11.423		
0178	11.091	11.128	11.362	11.348	11.481	11.448	11.600	11.548		
0180	11.216	11.253	11.487	11.473	11.606	11.573	11.725	11.673		
0182	11.341	11.378	11.612	11.598	11.731	11.698	11.850	11.798		
0184	11.466	11.503	11.737	11.723	11.856	11.823	11.975	11.923		
0186	11.591	11.628	11.862	11.848	11.981	11.948	12.100	12.048		
0188	11.716	11.753	11.987	11.973	12.106	12.073	12.225	12.173		
0190	11.841	11.878	12.112	12.098	12.231	12.198	12.350	12.298		
0192	11.966	12.003	12.237	12.223	12.356	12.323	12.475	12.423		
0194	12.091	12.128	12.362	12.348	12.481	12.448	12.600	12.548		
0196	12.216	12.253	12.487	12.473	12.606	12.573	12.725	12.673		
0198	12.341	12.378	12.612	12.598	12.731	12.698	12.850	12.798		
0200	12.466	12.503	12.737	12.723	12.856	12.823	12.975	12.923	+ 0.000	+ 0.016
0202	12.591	12.628	12.862	12.848	12.981	12.948	13.100	13.048	- 0.012	- 0.000
0204	12.716	12.753	12.987	12.973	13.106	13.073	13.225	13.173		
0206	12.841	12.878	13.112	13.098	13.231	13.198	13.350	13.298		
0208	12.966	13.003	13.237	13.223	13.356	13.323	13.475	13.423		
0210	13.091	13.128	13.362	13.348	13.481	13.448	13.600	13.548		
0212	13.216	13.253	13.487	13.473	13.606	13.573	13.725	13.673		
0214	13.341	13.378	13.612	13.598	13.731	13.698	13.850	13.798		
0216	13.466	13.503	13.737	13.723	13.856	13.823	13.975	13.923		
0218	13.591	13.628	13.862	13.848	13.981	13.948	14.100	14.048		
0220	13.716	13.753	13.987	13.973	14.106	14.073	14.225	14.173		
0222	13.841	13.878	14.112	14.098	14.231	14.198	14.350	14.298		
0224	13.966	14.003	14.237	14.223	14.356	14.323	14.475	14.423		
0226	14.091	14.128	14.362	14.348	14.481	14.448	14.600	14.548		
0228	14.216	14.253	14.487	14.473	14.606	14.573	14.725	14.673		
0230	14.341	14.378	14.612	14.598	14.731	14.698	14.850	14.798		
0232	14.466	14.503	14.737	14.723	14.856	14.823	14.975	14.923		
0234	14.591	14.628	14.862	14.848	14.981	14.948	15.100	15.048		
0236	14.716	14.753	14.987	14.973	15.106	15.073	15.225	15.173		
0238	14.841	14.878	15.112	15.098	15.231	15.198	15.350	15.298		
0240	14.966	15.003	15.237	15.223	15.356	15.323	15.475	15.423		
0242	15.091	15.128	15.362	15.358	15.481	15.458	15.600	15.558		
0244	15.216	15.253	15.487	15.483	15.606	15.583	15.725	15.683		
0246	15.341	15.378	15.612	15.608	15.731	15.708	15.850	15.808		
0248	15.466	15.503	15.737	15.733	15.856	15.833	15.975	15.933		
0250	15.591	15.628	15.862	15.858	15.981	15.958	16.100	16.058		
0252	15.716	15.753	15.987	15.983	16.106	16.083	16.225	16.183		
0254	15.841	15.878	16.112	16.108	16.231	16.208	16.350	16.308		
0256	15.966	16.003	16.237	16.233	16.356	16.333	16.475	16.433		
0258	16.091	16.128	16.362	16.358	16.481	16.458	16.600	16.558		
0260	16.216	16.253	16.487	16.483	16.606	16.583	16.725	16.683		
0262	16.341	16.378	16.612	16.608	16.731	16.708	16.850	16.808		
0264	16.466	16.503	16.737	16.733	16.856	16.833	16.975	16.933		
0266	16.591	16.628	16.862	16.858	16.981	16.958	17.100	17.058		
0268	16.716	16.753	16.987	16.983	17.106	17.083	17.225	17.183		
0270	16.841	16.878	17.112	17.108	17.231	17.208	17.350	17.308		
0272	16.966	17.003	17.237	17.233	17.356	17.333	17.475	17.433		
0274	17.091	17.128	17.362	17.358	17.481	17.458	17.600	17.558		
0276	17.216	17.253	17.487	17.483	17.606	17.583	17.725	17.683		
0278	17.341	17.378	17.612	17.608	17.731	17.708	17.850	17.808		
0280	17.466	17.503	17.737	17.733	17.856	17.833	17.975	17.933	+ 0.000	+ 0.020
0282	17.591	17.628	17.862	17.858	17.981	17.958	18.100	18.058	- 0.015	- 0.000
0284	17.716	17.753	17.987	17.983	18.106	18.083	18.225	18.183		
0286	17.841	17.878	18.112	18.108	18.231	18.208	18.350	18.308		
0288	17.966	18.003	18.237	18.233	18.356	18.333	18.475	18.433		
0290	18.091	18.128	18.362	18.358	18.481	18.458	18.600	18.558		
0292	18.216	18.253	18.487	18.483	18.606	18.583	18.725	18.683		
0294	18.341	18.378	18.612	18.608	18.731	18.708	18.850	18.808		
0296	18.466	18.503	18.737	18.733	18.856	18.833	18.975	18.933		
0298	18.591	18.628	18.862	18.858	18.981	18.958	19.100	19.058		
0300	18.716	18.753	18.987	18.983	19.106	19.083	19.225	19.183		
0302	18.841	18.878	19.112	19.108	19.231	19.208	19.350	19.308		
0304	18.966	19.003	19.237	19.233	19.356	19.333	19.475	19.433		
0306	19.091	19.128	19.362	19.358	19.481	19.458	19.600	19.558		
0308	19.216	19.253	19.487	19.483	19.606	19.583	19.725	19.683		
0310	19.341	19.378	19.612	19.608	19.731	19.708	19.850	19.808		
0312	19.466	19.503	19.737	19.733	19.856	19.833	19.975	19.933		
0314	19.591	19.628	19.862	19.858	19.981	19.958	20.100	20.058		
0316	19.716	19.753	19.987	19.983	20.106	20.083	20.225	20.183		
0318	19.841	19.878	20.112	20.108	20.231	20.208	20.350	20.308		

C-Seals Series 80

Boss C-Seal Description and Table

Designed specifically for AS5202 (AS4395)
type fittings & AND 10050 type bosses.

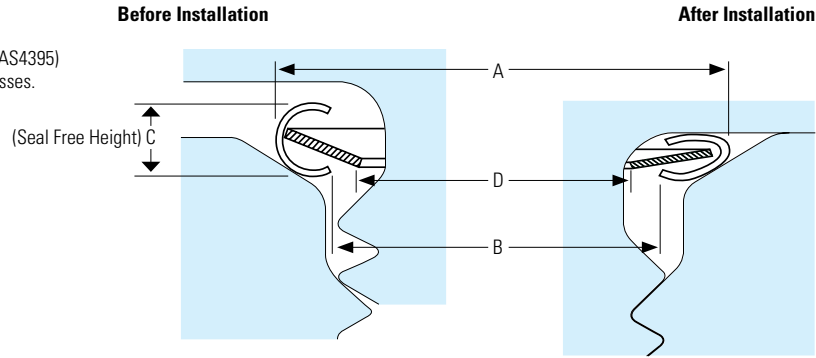

Exclusive Features

- **FOOLPROOF**, it's symmetrical and slips right on in either direction at installation.
- **SELF ALIGNING** and installs easily regardless of attitude of the boss.
- **EASY RE-USE**, it stays with the fitting after the first compression.
- **READILY "UNSCREWS"** from the fitting when you want to discard it.
- **LOAD IS NOT TRANSMITTED** from the fitting to the boss through the seal.
- **DOES NOT REQUIRE HIGH LOAD** to effect a tight seal.
- **SEAL IS PRESSURE ENERGIZED.**
- **NO MARKING OR FRETTING** of the boss or fitting.

8 0 1 A 5 1 - 0 0 3 6 - C

Boss Size No.	Diameter Dash No.	Seal O.D. (A)	Seal I.D. (B)	Seal FH (C)	Min.Liner I.D. (D)	Std. Material Thickness	Min. Torque Required (in-lbs)*
1	0001	0.319	0.240	0.046	0.219	0.006	180
2	0002	0.381	0.302	0.046	0.278	0.006	200
3	0003	0.444	0.365	0.046	0.341	0.006	220
4	0004	0.506	0.427	0.046	0.397	0.006	240
5	0005	0.569	0.490	0.046	0.459	0.006	270
6	0006	0.631	0.552	0.046	0.517	0.006	300
7	0004	0.694	0.615	0.046	0.579	0.006	370
8	0008	0.819	0.740	0.046	0.699	0.006	430
9	0009	0.882	0.803	0.046	0.761	0.006	505
10	0010	0.944	0.865	0.046	0.817	0.006	555
11	0011	1.100	1.021	0.046	0.932	0.006	625
12	0012	1.156	1.051	0.062	0.995	0.010	680
14	0014	1.281	1.176	0.062	1.120	0.010	800
16	0016	1.406	1.301	0.062	1.245	0.010	900
18	0018	1.593	1.488	0.062	1.432	0.010	1000
20	0020	1.718	1.613	0.062	1.557	0.010	1100
24	0024	1.968	1.863	0.062	1.807	0.010	1300
28	0028	2.343	2.238	0.062	2.182	0.010	1545
32	0032	2.594	2.489	0.062	2.432	0.010	1730

*Values based on seals made from Inconel X-750.

PLATING

See the plating information for standard C-Seals on page 10.

MATERIAL TYPE

Inconel X-750 is the recommended material available in order to minimize compression loads generated (see Load vs. Deflection graph on page 11 for load information).

E-Seal Sketch and Description

E-Seal Performance Capabilities:

- Flexible, suitable for applications with cyclic axial deflection
- Low leakage rates (but higher than C-Seal)
- Designed to operate primarily in the Elastic Range—Excellent springback and reusability characteristics
- Compression loads in the range of 10 to 50 PCI

The E-Seal is designed to meet the needs of high-pressure pulsations and large cavity deflections. It is used to seal cavities that have axial and some small radial deflections.

The E-Seal's relatively low compression load renders it not as well-suited for plating as a C-Seal. Available in two basic orientations, (Internal Pressure Face Type and External Pressure Face Type) the E-Seal offers a flexible, cost-effective, and reliable design.

Typical Applications and Locations

- Gas Turbine Engine Housing—sealing air at 400psi, +1100°F (+593°C), with .060" axial cavity deflections due to thermal conditions; cramped radial space
- High-Temperature Hydraulic component, pulsating

3000psi, +500°F (+260°C) fluid, .003" axial cavity deflections

- Fuel Nozzle—sealing air at 50psi, +700°F (+371°C); small diameter; cramped radial space
- Gas Turbine Engine—60" diameter, single convolution, sealing air at 50 psi, +900°F (+482°C), with .030" axial cavity deflections; two 180° arc segments; Tribaloy coated

Pressure Capability

The pressure capability of an E-Seal is a factor of the cross-section, material type, and diameter of the seal. Hoop restraint, or seal back support, is a must for extreme pressures.

Leakage Capability

Since the E-Seal has a relatively low force-to-compress and the use of platings to enhance leakage capability is ineffective, the E-Seal exhibits higher leakage rates than the C-Seal. Standard E-Seal cross-sections, however, can attain relatively low leakage rates, typically ranging around .010 SCFM (Standard Cubic Feet per Minute) per inch of diameter (for 32 RMS cavity surface finish) at operating conditions. This is achieved by taking advantage of the standard E-Seal's "re-curve" or radiused sealing surface.

Deflection Capability

E-Seals are designed to operate

primarily in the Elastic Region, though that may, in some cases, exhibit a small amount of permanent set. Typical axial deflection capabilities are shown in the *Load vs. Deflection* graph on page 23. This deflection capability indicates the maximum cavity axial cycling the section in question can accommodate on a continuous basis. This value can also be used to determine reuse capability. A general rule with E-Seals is that the seal can be reusable in its original cavity provided that the E-Seal axial Free Height is at least .005" greater than the maximum operating axial cavity height.

Applications exhibiting significant relative radial thermal growth between the seal and cavity (typically > .025"), or excessive radial movement during operation may be wear coated with Tribaloy T-800. This coating protects the seal from wear due to radial sliding, and also in cavities whose geometries can be harsh, i.e., segmented cavities, rough surface finishes, and hard cavity materials. **Figure 3A-3** shows where wear coating is typically applied.

Wear coating is not offered as an option in the standard part selection process. Please contact Eaton for applications where severe radial thermal movements are anticipated, and/or the cavity geometry would warrant its use.

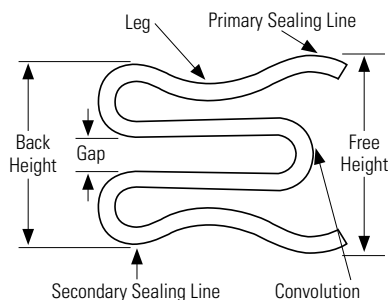
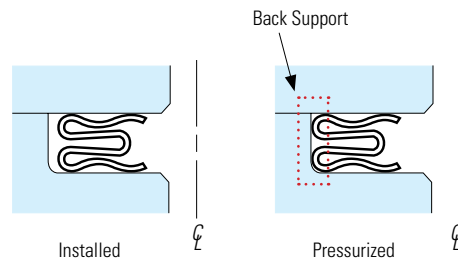

FIGURE 3A-1

Back Support



Standard E-Seals

Standard E-Seal Part Number Selection

The following pages act as a guide through a simple part number selection process. A selection can be based on the following criteria:

- 1. Seal Type and Orientation.**
Face type, internal or external pressure, Standard or High Flex Cross-Section
- 2. Seal Axial Free Height.**
Choose a seal size best suited to fit your cavity dimensions. If the cavity has not yet been defined, you can select a cross-section based on desired load, deflection and/or springback characteristics, and then use the diameter tables to design a cavity around your selection.
- 3. Material Type.** As with the Seal Axial Free Height selection, the selection of Material Type will be determined by the maximum operating temperature.
- 4. Plating.** Though plating choices do exist, they do not aid when used on E-Seals due to the E-Seals lower force-to-compress.
- 5. Diameter Dash Number.**
This reference is the size of the seal and cavity. Please note, we can also provide "in-between" sizes, as well as larger sizes not included in this catalog. Please note,

not all sizes referenced are in stock. Please consult Eaton at 301-937-4010 to check availability.

- 6. Catalog Code.** Always designated by a "C"

Semi-Static Seals

The type of cross-section that is best suited for an application is influenced by three factors: the cavity geometry, its operational movements, and load and leakage requirements.

The following questions, once answered, will address selecting the correct type of cross-section:

What is the Cavity Geometry?

- sealing occurs on the axial faces of the cavity
- cyclical movements due to thermal, pressure, and/or mechanical effects occur in the axial direction
- typical load-to-compress in the range of 10-80 PCI
- typical leakage rates approximately .010 SCFM per inch circumference

See Standard E-Seals section, pages 22-31 for more information on E-Seal standard part number selection.

See U-Plex Seal section, pages 42-44 for more information on U-Plex standard part number selection.

- sealing occurs on the radial

faces of the cavity, i.e., concentric walls of a shaft

- movements due to thermal, pressure, and/or mechanical effects occur in the radial and/or axial direction
- typical load-to-compress in the range of 250-400 PCI
- typical leakage rates approximately .010 SCFM per inch circumference

FIGURE 1-13

Typical E-Seal and U-Plex Seal Cavities

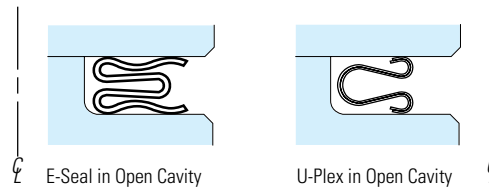

FIGURE 1-14

Typical Wave-Seal and Twist-Flex Cavities

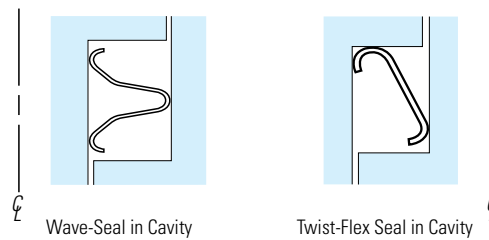

FIGURE 3A-2

Secondary Sealing Line (Duct Applications)

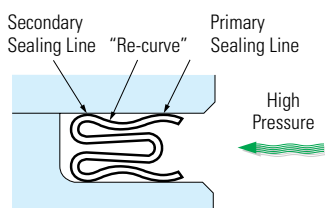
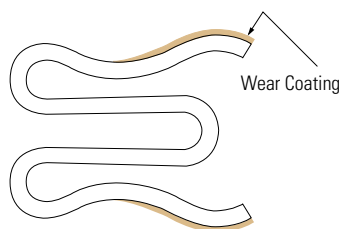

FIGURE 3A-3

Wear Coating



Standard E-Seals

After selecting your part number, expedite your order by filling out a copy of the appropriate drawing form in the attached Appendix and faxing to the number on the form. Instructions on filling out the drawing form can also be found in the appendix.

6 6 4 - 9 0 - 0 0 3 6 - C

CATALOG CODE

Only option is -C.

DIAMETER DASH NUMBERS

See Tables on pages 24-31 for four-digit diameter designation code.

PLATING

Only option is 0-. (Due to low force-to-compress of the E-Seal, plating is ineffective and will not deform (see introduction).

MATERIAL TYPE

	Material	Remarks—operating temperature (T)
9:	Inconel 718	+1000°F < T < +1200°F (+649°C)
W:	Waspaloy	+1200°F < T < +1400°F† (+760°C)

† Please consult factory for all applications operating above +1350°F (+732°C).

SEAL AXIAL FREE HEIGHT

P/N Code	3-	4-	5-
Free Height	3/32"	1/8"	3/16"
Series 66 & 67	.102 ± .002	.132 ± .003	.218 ± .005
Std. Thickness	.010 ± .001	.015 ± .001	.015 ± .001
Series 68 & 69	.108 ± .005	.140 ± .005	N/A
Std. Thickness	.0095 ± .001	.012 ± .001	N/A

Thicknesses are prior to forming.

SEAL TYPE AND ORIENTATION

- 66: standard internal pressure face type
- 67: standard external pressure face type
- 68: high-flex internal pressure face type
- 69: high-flex external pressure face type

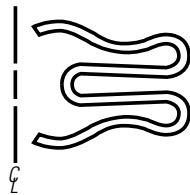

internal (66 & 68)

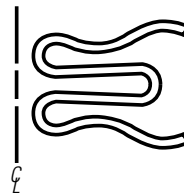

external (67 & 69)

Load (FTC₀) vs. Deflection

FH = Free Height

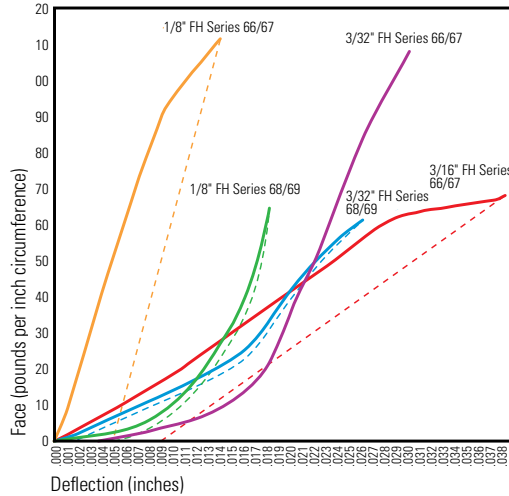

The following Scaling Factors are to be used as multipliers of the values from the graph, to customize seal performance to an application's particular conditions. To obtain approximate force-to-compress (FTC) value, simply multiply the load obtained from the graphs (FTC₀) by the multipliers below that conform to your requirements.

LOAD AND SPRINGBACK SCALING FACTORS

FTC = Force to Compress (your application's specifications)

SEAL MATERIAL

Waspaloy: $FTC = FTC_0 \times 0.83$

Values based on a seal of 4" mean diameter and fully heat treated INCONEL 718, standard material thickness.

Note: Dashed lines represent the un-loading of the seal and indicate what permanent set, if any, the seal may experience.

Typical Diameter vs. Deflection

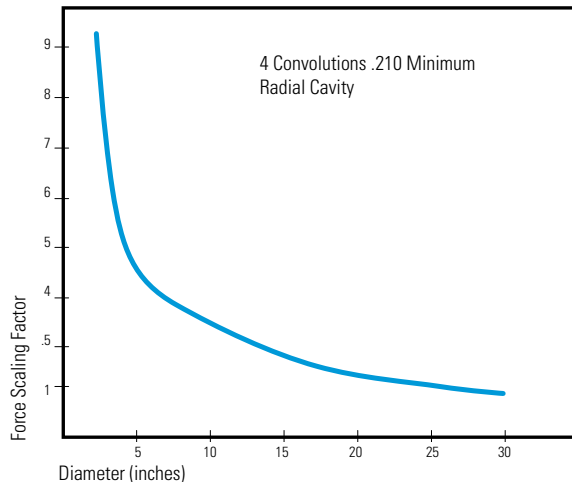

This graph illustrates the effect of diameter hoop stress on force-to-compress; the smaller the diameter, the greater the effect. For specifics concerning your application, below 5" in diameter, please consult with your Sales Engineer.

Standard E-Seals Series 66

Standard Internal Pressure E-Seal Tables

DIAMETER DASH NO.	CAVITY I.D. MAX. (E)	SEAL I.D. AVG. MIN. (B)	3/32" FREE HEIGHT		1/8" FREE HEIGHT		3/16" FREE HEIGHT		TOLERANCES	
			CAVITY O.D. (D)	SEAL O.D. AVG. (A)	CAVITY O.D. (D)	SEAL O.D. AVG. (A)	CAVITY O.D. (D)	SEAL O.D. AVG. (A)	CAVITY O.D. (D)	SEAL O.D. (A)
			C=	.102 ± .002						
			F=	.087 ± .001						
			R MAX=	.030						
0010	0.625	0.628	0.813	0.809	***	***	***	***		
0011	0.687	0.690	0.875	0.871	***	***	***	***		
0012	0.750	0.753	0.938	0.934	***	***	***	***		
0013	0.812	0.815	1.000	0.996	***	***	***	***		
0014	0.875	0.878	1.063	1.059	1.125	1.122	***	***		
0015	0.937	0.940	1.125	1.121	1.187	1.184	***	***		
0016	1.000	1.003	1.188	1.184	1.250	1.247	***	***		
0017	1.062	1.065	1.250	1.246	1.312	1.309	***	***		
0018	1.125	1.128	1.313	1.309	1.375	1.372	***	***		
0019	1.187	1.190	1.375	1.371	1.437	1.434	***	***		
0020	1.250	1.253	1.438	1.434	1.500	1.497	***	***	+ 0.002	+ 0.000
0021	1.312	1.315	1.500	1.496	1.562	1.559	***	***	- 0.000	- 0.006
0022	1.375	1.378	1.563	1.559	1.625	1.622	***	***		
0023	1.437	1.440	1.625	1.621	1.687	1.684	***	***		
0024	1.500	1.503	1.688	1.684	1.750	1.747	***	***		
0025	1.562	1.565	1.750	1.746	1.812	1.809	***	***		
0026	1.625	1.628	1.813	1.809	1.875	1.872	***	***		
0027	1.687	1.690	1.875	1.871	1.937	1.934	***	***		
0028	1.750	1.753	1.938	1.934	2.000	1.997	***	***		
0029	1.812	1.815	2.000	1.996	2.062	2.059	***	***		
0030	1.875	1.878	2.063	2.059	2.125	2.122	***	***		
0031	1.937	1.940	2.125	2.121	2.187	2.184	***	***		
0032	2.000	2.003	2.188	2.184	2.250	2.247	***	***		
0033	2.062	2.065	2.250	2.246	2.312	2.309	***	***		
0034	2.125	2.128	2.313	2.309	2.375	2.372	***	***		
0035	2.187	2.190	2.375	2.371	2.437	2.434	***	***		
0036	2.250	2.253	2.438	2.434	2.500	2.497	***	***		
0037	2.312	2.315	2.500	2.496	2.562	2.559	***	***		
0038	2.375	2.378	2.563	2.559	2.625	2.622	***	***	+ 0.003	+ 0.000
0039	2.437	2.440	2.625	2.621	2.687	2.684	***	***	- 0.000	- 0.008
0040	2.500	2.503	2.688	2.684	2.750	2.747	***	***		
0041	2.562	2.565	2.750	2.746	2.812	2.809	***	***		
0042	2.625	2.628	2.813	2.809	2.875	2.872	***	***		
0043	2.687	2.690	2.875	2.871	2.937	2.934	***	***		
0044	2.750	2.753	2.938	2.934	3.000	2.997	***	***		
0045	2.812	2.815	3.000	2.996	3.062	3.059	***	***		
0046	2.875	2.878	3.063	3.059	3.125	3.122	***	***		
0047	2.937	2.940	3.125	3.121	3.187	3.184	***	***		
0048	3.000	3.003	3.188	3.184	3.250	3.247	3.375	3.372		
0049	3.062	3.065	3.250	3.246	3.312	3.309	3.437	3.434		
0050	3.125	3.128	3.313	3.309	3.375	3.372	3.500	3.497		
0051	3.187	3.190	3.375	3.371	3.437	3.434	3.562	3.559		
0052	3.250	3.253	3.438	3.434	3.500	3.497	3.625	3.622		
0053	3.312	3.315	3.500	3.496	3.562	3.559	3.687	3.684		
0054	3.375	3.378	3.563	3.559	3.625	3.622	3.750	3.747		
0055	3.437	3.440	3.625	3.621	3.687	3.684	3.812	3.809		
0056	3.500	3.503	3.688	3.684	3.750	3.747	3.875	3.872		
0057	3.562	3.565	3.750	3.746	3.812	3.809	3.937	3.934		
0058	3.625	3.628	3.813	3.809	3.875	3.872	4.000	3.997		
0059	3.687	3.690	3.875	3.871	3.937	3.934	4.062	4.059		
0060	3.750	3.753	3.938	3.934	4.000	3.997	4.125	4.122		
0061	3.812	3.815	4.000	3.996	4.062	4.059	4.187	4.184		
0062	3.875	3.878	4.063	4.059	4.125	4.122	4.250	4.247		
0063	3.937	3.940	4.125	4.121	4.187	4.184	4.312	4.309	+ 0.004	+ 0.000
0064	4.000	4.003	4.188	4.184	4.250	4.247	4.375	4.372	- 0.000	- 0.010
0065	4.062	4.065	4.250	4.246	4.312	4.309	4.437	4.434		
0066	4.125	4.128	4.313	4.309	4.375	4.372	4.500	4.497		
0067	4.187	4.190	4.375	4.371	4.437	4.434	4.562	4.559		
0068	4.250	4.253	4.438	4.434	4.500	4.497	4.625	4.622		
0069	4.312	4.315	4.500	4.496	4.562	4.559	4.687	4.684		
0070	4.375	4.378	4.563	4.559	4.625	4.622	4.750	4.747		
0071	4.437	4.440	4.625	4.621	4.687	4.684	4.812	4.809		
0072	4.500	4.503	4.688	4.684	4.750	4.747	4.875	4.872		
0073	4.562	4.565	4.750	4.746	4.812	4.809	4.937	4.934		
0074	4.625	4.628	4.813	4.809	4.875	4.872	5.000	4.997		
0075	4.687	4.690	4.875	4.871	4.937	4.934	5.062	5.059		
0076	4.750	4.753	4.938	4.934	5.000	4.997	5.125	5.122		

Standard E-Seals Series 66

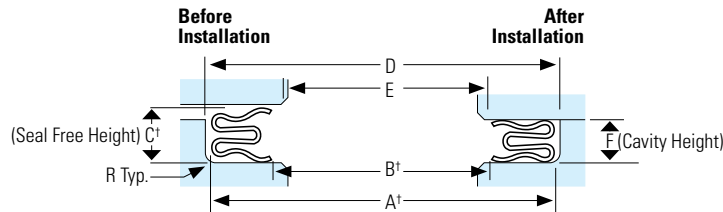

Diagram depicts an open cavity configuration; seals work equally well in a closed cavity configuration with the same envelope dimensions. Seal dimensions are in un-restrained state.

¹Free State

DIAMETER DASH NO.	CAVITY I.D. MAX. (E)	SEAL I.D. AVG. MIN. (B)	3/32" FREE HEIGHT		1/8" FREE HEIGHT		3/16" FREE HEIGHT		CAVITY O.D. (D)	SEAL O.D. (A)			
			C=	F=	R MAX=	C=	F=	R MAX=			C=	F=	R MAX=
			.102 ± .002	.087 ± .001	.030	.132 ± .003	.118 ± .002	.045	.218 ± .005	.181 ± .002	.070	TOLERANCES	
0077	4.782	4.815	5.000	4.997	5.062	5.059	5.187	5.184					
0078	4.875	4.878	5.062	5.059	5.125	5.122	5.250	5.247					
0079	4.937	4.940	5.125	5.122	5.187	5.184	5.312	5.309	+ 0.004	+ 0.000			
0080	5.000	5.003	5.187	5.187	5.250	5.247	5.375	5.372	- 0.000	- 0.010			
0081	5.062	5.065	5.250	5.247	5.312	5.309	5.437	5.434					
0082	5.125	5.128	5.312	5.309	5.375	5.372	5.500	5.497					
0083	5.187	5.190	5.375	5.372	5.437	5.434	5.562	5.559					
0084	5.250	5.253	5.437	5.434	5.500	5.497	5.625	5.622					
0085	5.312	5.315	5.500	5.497	5.562	5.559	5.687	5.684					
0086	5.375	5.378	5.562	5.559	5.625	5.622	5.750	5.747					
0087	5.437	5.440	5.625	5.622	5.687	5.684	5.812	5.809					
0088	5.500	5.503	5.687	5.684	5.750	5.747	5.875	5.872					
0089	5.562	5.565	5.750	5.747	5.812	5.809	5.937	5.934					
0090	5.625	5.628	5.812	5.809	5.875	5.872	6.000	5.997					
0092	5.750	5.753	5.937	5.934	6.000	5.997	6.125	6.122	+ 0.006	+ 0.000			
0094	5.875	5.878	6.062	6.059	6.125	6.122	6.250	6.247	- 0.000	- 0.010			
0096	6.000	6.003	6.187	6.184	6.250	6.247	6.375	6.372					
0098	6.125	6.128	6.312	6.309	6.375	6.372	6.497	6.500					
0100	6.250	6.253	6.437	6.434	6.500	6.497	6.625	6.622					
0102	6.375	6.378	6.562	6.559	6.625	6.622	6.750	6.747					
0104	6.500	6.503	6.687	6.684	6.750	6.747	6.875	6.872					
0106	6.625	6.628	6.812	6.809	6.875	6.872	7.000	6.997					
0108	6.750	6.753	6.937	6.934	7.000	6.997	7.125	7.122					
0110	6.875	6.878	7.062	7.059	7.125	7.122	7.250	7.247					
0112	7.000	7.003	7.187	7.184	7.250	7.247	7.375	7.372					
0114	7.125	7.128	7.312	7.309	7.375	7.372	7.500	7.497					
0116	7.250	7.253	7.437	7.434	7.500	7.497	7.625	7.622					
0118	7.375	7.378	7.562	7.559	7.625	7.622	7.750	7.747					
0120	7.500	7.503	7.687	7.684	7.750	7.747	7.875	7.872					
0122	7.625	7.628	7.812	7.809	7.875	7.872	8.000	7.997					
0124	7.687	7.690	7.937	7.934	8.000	7.997	8.125	8.122					
0126	7.812	7.815	8.062	8.059	8.125	8.122	8.250	8.247					
0128	7.937	7.940	8.187	8.184	8.250	8.247	8.375	8.372					
0130	8.062	8.065	8.312	8.309	8.375	8.372	8.500	8.497					
0132	8.187	8.190	8.437	8.434	8.500	8.497	8.625	8.622					
0134	8.312	8.315	8.562	8.559	8.625	8.622	8.750	8.747	+ 0.008	+ 0.000			
0136	8.437	8.440	8.687	8.684	8.750	8.747	8.875	8.872	- 0.000	- 0.010			
0138	8.562	8.565	8.812	8.809	8.875	8.872	9.000	8.997					
0140	8.687	8.690	8.937	8.934	9.000	8.997	9.125	9.122					
0142	8.812	8.815	9.062	9.059	9.125	9.122	9.250	9.247					
0144	8.937	8.940	9.187	9.184	9.250	9.247	9.375	9.372					
0146	9.062	9.065	9.312	9.309	9.375	9.372	9.500	9.497					
0148	9.187	9.190	9.437	9.434	9.500	9.497	9.625	9.622					
0150	9.312	9.315	9.562	9.559	9.625	9.622	9.750	9.747					
0152	9.437	9.440	9.687	9.684	9.750	9.747	9.875	9.872					
0154	9.562	9.565	9.812	9.809	9.875	9.872	10.000	9.997					
0156	9.687	9.690	9.937	9.934	10.000	9.997	10.125	10.122					
0158	9.812	9.815	10.062	10.059	10.125	10.122	10.250	10.247					
0160	9.937	9.940	10.187	10.184	10.250	10.247	10.375	10.372					
0162	10.062	10.065	10.312	10.309	10.375	10.372	10.500	10.497					
0164	10.187	10.190	10.437	10.434	10.500	10.497	10.625	10.622					
0166	10.312	10.315	10.562	10.559	10.625	10.622	10.750	10.747					
0168	10.437	10.440	10.687	10.684	10.750	10.747	10.875	10.872					
0170	10.562	10.565	10.812	10.809	10.875	10.872	11.000	10.997					
0172	10.687	10.690	10.937	10.934	11.000	10.997	11.125	11.122					
0174	10.812	10.815	11.062	11.059	11.125	11.122	11.250	11.247					
0176	10.937	10.940	11.187	11.184	11.250	11.247	11.375	11.372					
0178	11.062	11.065	11.312	11.309	11.375	11.372	11.500	11.497	+ 0.012	+ 0.000			
0180	11.187	11.190	11.437	11.434	11.500	11.497	11.625	11.622	- 0.000	- 0.012			
0182	11.312	11.315	11.562	11.559	11.625	11.622	11.750	11.747					
0184	11.437	11.440	11.687	11.684	11.750	11.747	11.875	11.872					
0186	11.562	11.565	11.812	11.809	11.875	11.872	12.000	11.997					
0188	11.687	11.690	11.937	11.934	12.000	11.997	12.125	12.122					
0190	11.812	11.815	12.062	12.059	12.125	12.122	12.250	12.247					
0192	11.937	11.940	12.187	12.184	12.250	12.247	12.375	12.372					
0194	12.062	12.065	12.312	12.309	12.375	12.372	12.500	12.497					
0196	12.187	12.190	12.437	12.434	12.500	12.497	12.625	12.622					
0198	12.312	12.315	12.562	12.559	12.625	12.622	12.750	12.747					

Standard E-Seals Series 67

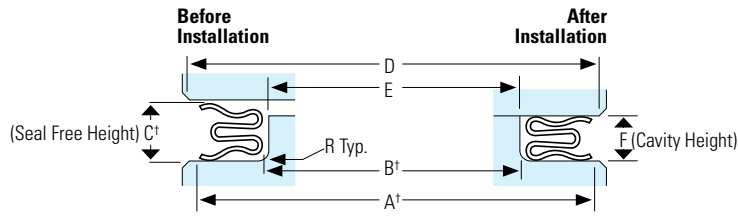

Diagram depicts an open cavity configuration; seals work equally well in a closed cavity configuration with the same envelope dimensions. Seal dimensions are in un-restrained state.
*Free State

DIAMETER DASH NO.	CAVITY I.D. (E)	SEAL I.D. AVG. (B)	3/32" FREE HEIGHT		1/8" FREE HEIGHT		3/16" FREE HEIGHT		CAVITY I.D. (E)	SEAL I.D. (B)
			CAVITY O.D. MIN. (D)	SEAL O.D. AVG. MAX. (A)	CAVITY O.D. MIN. (D)	SEAL O.D. AVG. MAX. (A)	CAVITY O.D. MIN. (D)	SEAL O.D. AVG. MAX. (A)		
			C=	.102 ± .002		.132 ± .003		.218 ± .005		
			F=	.087 ± .001		.118 ± .002		.181 ± .002		
			R MAX=	.030		.045		.070		
									TOLERANCES	
0076	4.750	4.753	4.938	4.934	5.000	4.997	5.125	5.122		
0077	4.812	4.815	5.000	4.996	5.062	5.059	5.187	5.184		
0078	4.875	4.878	5.063	5.059	5.125	5.122	5.250	5.247	+ 0.000	+ 0.010
0079	4.937	4.940	5.125	5.121	5.187	5.184	5.312	5.309	- 0.004	- 0.000
0080	5.000	5.003	5.188	5.184	5.250	5.247	5.375	5.372		
0081	5.062	5.065	5.250	5.246	5.312	5.309	5.437	5.434		
0082	5.125	5.128	5.313	5.309	5.375	5.372	5.500	5.497		
0083	5.187	5.190	5.375	5.371	5.437	5.434	5.562	5.559		
0084	5.250	5.253	5.438	5.434	5.500	5.497	5.625	5.622		
0085	5.312	5.315	5.500	5.496	5.562	5.559	5.687	5.684		
0086	5.375	5.378	5.563	5.559	5.625	5.622	5.750	5.747		
0087	5.437	5.440	5.625	5.621	5.687	5.684	5.812	5.809		
0088	5.500	5.503	5.688	5.684	5.750	5.747	5.875	5.872		
0089	5.562	5.565	5.750	5.746	5.812	5.809	5.937	5.934		
0090	5.625	5.628	5.813	5.809	5.875	5.872	6.000	5.997	+ 0.000	+ 0.012
0092	5.750	5.753	5.938	5.934	6.000	5.997	6.125	6.122	- 0.006	- 0.000
0094	5.875	5.878	6.063	6.059	6.125	6.122	6.250	6.247		
0096	6.000	6.003	6.188	6.184	6.250	6.247	6.375	6.372		
0098	6.125	6.128	6.313	6.309	6.375	6.372	6.500	6.497		
0100	6.250	6.253	6.438	6.434	6.500	6.497	6.625	6.622		
0102	6.375	6.378	6.563	6.559	6.625	6.622	6.750	6.747		
0104	6.500	6.503	6.688	6.684	6.750	6.747	6.875	6.872		
0106	6.625	6.628	6.813	6.809	6.875	6.872	7.000	6.997		
0108	6.750	6.753	6.938	6.934	7.000	6.997	7.125	7.122		
0110	6.875	6.878	7.063	7.059	7.125	7.122	7.250	7.247		
0112	7.000	7.003	7.188	7.184	7.250	7.247	7.375	7.372		
0114	7.125	7.128	7.313	7.309	7.375	7.372	7.500	7.497		
0116	7.250	7.253	7.438	7.434	7.500	7.497	7.625	7.622		
0118	7.375	7.378	7.563	7.559	7.625	7.622	7.750	7.747		
0120	7.500	7.503	7.688	7.684	7.750	7.747	7.875	7.872		
0122	7.625	7.628	7.813	7.809	7.875	7.872	8.000	7.997		
0124	7.750	7.753	7.938	7.934	8.000	7.997	8.125	8.122		
0126	7.875	7.878	8.063	8.059	8.125	8.122	8.250	8.247		
0128	8.000	8.003	8.188	8.184	8.250	8.247	8.375	8.372		
0130	8.125	8.128	8.313	8.309	8.375	8.372	8.500	8.497		
0132	8.250	8.253	8.438	8.434	8.500	8.497	8.625	8.622		
0134	8.375	8.378	8.563	8.559	8.625	8.622	8.750	8.747	+ 0.000	+ 0.014
0136	8.500	8.503	8.688	8.684	8.750	8.747	8.875	8.872	- 0.008	- 0.000
0138	8.625	8.628	8.813	8.809	8.875	8.872	9.000	8.997		
0140	8.750	8.753	8.938	8.934	9.000	8.997	9.125	9.122		
0142	8.875	8.878	9.063	9.059	9.125	9.122	9.250	9.247		
0144	9.000	9.003	9.188	9.184	9.250	9.247	9.375	9.372		
0146	9.125	9.128	9.313	9.309	9.375	9.372	9.500	9.497		
0148	9.250	9.253	9.438	9.434	9.500	9.497	9.625	9.622		
0150	9.375	9.378	9.563	9.559	9.625	9.622	9.750	9.747		
0152	9.500	9.503	9.688	9.684	9.750	9.747	9.875	9.872		
0154	9.625	9.628	9.813	9.809	9.875	9.872	10.000	9.997		
0156	9.750	9.753	9.938	9.934	10.000	9.997	10.125	10.122		
0158	9.875	9.878	10.063	10.059	10.125	10.122	10.250	10.247		
0160	10.000	10.003	10.188	10.184	10.250	10.247	10.375	10.372		
0162	10.125	10.128	10.313	10.309	10.375	10.372	10.500	10.497		
0164	10.250	10.253	10.438	10.434	10.500	10.497	10.625	10.622		
0166	10.375	10.378	10.563	10.559	10.625	10.622	10.750	10.747		
0168	10.500	10.503	10.688	10.684	10.750	10.747	10.875	10.872		
0170	10.625	10.628	10.813	10.809	10.875	10.872	11.000	10.997		
0172	10.750	10.753	10.938	10.934	11.000	10.997	11.125	11.122		
0174	10.875	10.878	11.063	11.059	11.125	11.122	11.250	11.247		
0176	11.000	11.003	11.188	11.184	11.250	11.247	11.375	11.372	+ 0.000	+ 0.020
0178	11.125	11.128	11.313	11.309	11.375	11.372	11.500	11.497	- 0.012	- 0.000
0180	11.250	11.253	11.438	11.434	11.500	11.497	11.625	11.622		
0182	11.375	11.378	11.563	11.559	11.625	11.622	11.750	11.747		
0184	11.500	11.503	11.688	11.684	11.750	11.747	11.875	11.872		
0186	11.625	11.628	11.813	11.809	11.875	11.872	12.000	11.997		
0188	11.750	11.753	11.938	11.934	12.000	11.997	12.125	12.122		
0190	11.875	11.878	12.063	12.059	12.125	12.122	12.250	12.247		
0192	12.000	12.003	12.188	12.184	12.250	12.247	12.375	12.372		

Standard E-Seals Series 68

3/32" FREE HEIGHT **1/8" FREE HEIGHT**
C= .108 ± .005 **.140 ± .005**
F= .087 ± .001 **.118 ± .002**
R MAX= .030 **.045**

TOLERANCES

High Flex Internal Pressure E-Seal Tables

DIAMETER DASH NO.	CAVITY I.D. MAX. (E)	SEAL I.D. AVG. MIN. (B)	CAVITY O.D. (D)	SEAL O.D. AVG. (A)	CAVITY O.D. (D)	SEAL O.D. AVG. (A)	CAVITY O.D. (D)	SEAL O.D. (A)
0015	0.937	0.947	1.243	1.238	***	***		
4136	0.965	0.975	1.271	1.266	***	***		
0016	1.000	1.012	1.308	1.303	***	***		
0017	1.062	1.074	1.370	1.365	***	***		
0018	1.125	1.137	1.433	1.428	***	***		
0019	1.187	1.199	1.495	1.490	***	***		
4161	1.213	1.225	1.521	1.516	***	***		
0020	1.250	1.262	1.558	1.553	***	***		
0021	1.312	1.320	1.620	1.615	1.717	1.712		
0022	1.375	1.383	1.683	1.678	1.780	1.775		
0023	1.437	1.445	1.745	1.740	1.842	1.837		
3174	1.446	1.454	1.754	1.749	1.851	1.846	+0.002	+0.000
4186	1.463	1.471	1.771	1.766	1.868	1.863	-0.000	-0.008
0024	1.500	1.508	1.808	1.803	1.905	1.900		
0025	1.562	1.570	1.870	1.865	1.967	1.962		
0026	1.625	1.633	1.933	1.928	2.030	2.025		
0027	1.687	1.695	1.995	1.990	2.092	2.087		
4211	1.725	1.721	2.021	2.016	2.118	2.113		
0028	1.750	1.758	2.058	2.053	2.155	2.150		
0029	1.812	1.820	2.120	2.115	2.217	2.212		
0030	1.875	1.883	2.183	2.178	2.280	2.275		
0031	1.937	1.945	2.245	2.240	2.342	2.337		
3224	1.946	1.954	2.254	2.249	2.351	2.346		
4236	1.963	1.971	2.271	2.266	2.368	2.363		
0032	2.000	2.008	2.310	2.305	2.407	2.402		
0033	2.062	2.070	2.372	2.367	2.469	2.464		
0034	2.125	2.133	2.435	2.430	2.532	2.527		
0035	2.187	2.195	2.497	2.492	2.594	2.589		
4261	2.212	2.220	2.522	2.517	2.619	2.614		
0036	2.250	2.258	2.560	2.555	2.657	2.652		
0037	2.312	2.320	2.622	2.617	2.719	2.714		
0038	2.375	2.383	2.685	2.680	2.782	2.777		
0039	2.437	2.445	2.747	2.742	2.844	2.839		
3274	2.444	2.463	2.754	2.749	2.862	2.857		
4286	2.462	2.470	2.772	2.767	2.869	2.864		
0040	2.500	2.508	2.810	2.805	2.907	2.902	+0.003	+0.000
0041	2.562	2.570	2.872	2.867	2.969	2.964	-0.000	-0.010
0042	2.625	2.633	2.935	2.930	3.032	3.027		
0043	2.687	2.691	2.997	2.992	3.090	3.085		
4311	2.712	2.720	3.022	3.017	3.119	3.114		
0044	2.750	2.758	3.060	3.055	3.157	3.152		
0045	2.812	2.820	3.122	3.117	3.219	3.214		
0046	2.875	2.883	3.185	3.180	3.282	3.277		
0047	2.937	2.945	3.247	3.242	3.344	3.339		
4336	2.940	2.970	3.272	3.267	3.369	3.364		
0048	3.000	3.010	3.312	3.307	3.409	3.404		
0049	3.062	3.072	3.374	3.369	3.471	3.466		
0050	3.125	3.135	3.437	3.432	3.534	3.529		
0051	3.187	3.195	3.499	3.494	3.596	3.591		
4361	3.210	3.218	3.522	3.517	3.619	3.614		
0052	3.250	3.258	3.562	3.557	3.659	3.654		
0053	3.312	3.320	3.624	3.619	3.721	3.716		
0054	3.375	3.383	3.687	3.682	3.784	3.779		
0055	3.437	3.445	3.749	3.744	3.846	3.841		
4386	3.461	3.469	3.773	3.768	3.870	3.865		
0056	3.500	3.508	3.812	3.807	3.909	3.904		
3386	3.558	3.566	3.870	3.865	3.967	3.962		
0057	3.562	3.570	3.874	3.869	3.971	3.966		
0058	3.625	3.633	3.937	3.932	4.034	4.029	+0.004	+0.000
0059	3.687	3.695	3.999	3.994	4.096	4.091	-0.000	-0.012
0060	3.750	3.758	4.062	4.057	4.159	4.154		
0061	3.812	3.820	4.124	4.119	4.221	4.216		
0062	3.875	3.883	4.187	4.182	4.284	4.279		
0063	3.937	3.945	4.249	4.244	4.346	4.341		
4436	3.961	3.969	4.273	4.268	4.370	4.365		
0064	4.000	4.010	4.314	4.309	4.411	4.406		
0065	4.062	4.072	4.376	4.371	4.473	4.468		

Standard E-Seals Series 68

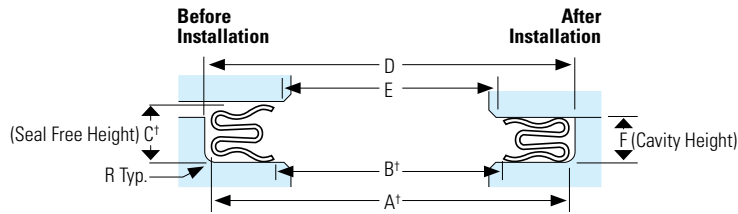

	3/32" FREE HEIGHT	1/8" FREE HEIGHT
C=	.108 ± .005	.140 ± .005
F=	.087 ± .001	.118 ± .002
R MAX=	.030	.045

TOLERANCES

DIAMETER DASH NO.	CAVITY I.D. MAX. (E)	SEAL I.D. AVG. MIN. (B)	CAVITY O.D. (D)	SEAL O.D. AVG. (A)	CAVITY O.D. (D)	SEAL O.D. AVG. (A)	CAVITY O.D. (D)	SEAL O.D. (A)
0066	4.103	4.133	4.439	4.434	4.536	4.531		
0067	4.165	4.195	4.501	4.496	4.598	4.593		
0068	4.228	4.258	4.564	4.559	4.661	4.656		
0069	4.290	4.320	4.626	4.621	4.723	4.718		
0070	4.353	4.383	4.689	4.684	4.786	4.781		
0071	4.415	4.445	4.751	4.746	4.848	4.843		
4486	4.437	4.467	4.773	4.768	4.870	4.865		
0072	4.478	4.508	4.814	4.809	4.911	4.906	+ 0.005	+ 0.000
0073	4.540	4.570	4.876	4.871	4.973	4.968	- 0.000	- 0.012
0074	4.603	4.633	4.939	4.934	5.036	5.031		
0075	4.665	4.695	5.001	4.996	5.098	5.093		
0076	4.728	4.758	5.064	5.059	5.161	5.156		
0077	4.790	4.820	5.126	5.121	5.223	5.218		
0078	4.853	4.883	5.189	5.184	5.286	5.281		
0079	4.915	4.945	5.251	5.246	5.348	5.343		
4536	4.939	4.969	5.275	5.270	5.372	5.367		
0080	4.978	5.008	5.316	5.311	5.413	5.408		
0081	5.040	5.070	5.378	5.373	5.475	5.470		
0082	5.103	5.133	5.441	5.436	5.538	5.533		
0083	5.165	5.195	5.503	5.498	5.600	5.595		
0084	5.228	5.258	5.566	5.561	5.663	5.658		
0085	5.290	5.320	5.628	5.623	5.725	5.720		
0086	5.353	5.383	5.691	5.686	5.788	5.783		
0087	5.415	5.445	5.753	5.748	5.850	5.845		
4586	5.437	5.467	5.775	5.770	5.872	5.867		
0088	5.478	5.508	5.816	5.811	5.913	5.908		
0089	5.540	5.570	5.878	5.873	5.975	5.970		
0090	5.603	5.633	5.941	5.936	6.038	6.033		
0092	5.728	5.758	6.066	6.061	6.163	6.158	+ 0.006	+ 0.000
0094	5.853	5.883	6.191	6.186	6.288	6.283	- 0.000	- 0.014
4636	5.937	5.967	6.275	6.270	6.372	6.367		
0096	5.980	6.010	6.318	6.313	6.415	6.410		
4646	6.037	6.067	6.375	6.370	6.474	6.469		
0098	6.103	6.133	6.441	6.436	6.540	6.535		
0100	6.228	6.258	6.566	6.561	6.665	6.660		
0102	6.353	6.383	6.691	6.686	6.790	6.785		
0104	6.478	6.508	6.816	6.811	6.915	6.910		
0106	6.603	6.633	6.941	6.936	7.040	7.035		
0108	6.728	6.758	7.066	7.061	7.165	7.160		
0110	6.853	6.883	7.191	7.186	7.290	7.285		
0112	6.980	7.010	7.318	7.313	7.417	7.412		
0114	7.103	7.133	7.441	7.436	7.542	7.537		
0116	7.228	7.258	7.566	7.561	7.667	7.662		
0118	7.353	7.383	7.691	7.686	7.792	7.787		
0120	7.478	7.508	7.816	7.811	7.917	7.912	+ 0.008	+ 0.000
0122	7.633	7.663	7.971	7.966	8.072	8.067	- 0.000	- 0.016
0124	7.728	7.758	8.066	8.061	8.167	8.162		
0126	7.853	7.883	8.191	8.186	8.292	8.287		
0128	7.980	8.010	8.318	8.313	8.419	8.414		
0130	8.103	8.133	8.441	8.436	8.544	8.539		
0132	8.228	8.258	8.566	8.561	8.669	8.664		
0134	8.353	8.383	8.691	8.686	8.794	8.789		
0136	8.478	8.508	8.816	8.811	8.919	8.914	+ 0.009	+ 0.000
0138	8.603	8.633	8.941	8.936	9.044	9.039	- 0.000	- 0.018
0140	8.728	8.758	9.066	9.061	9.169	9.164		
0142	8.853	8.883	9.191	9.186	9.294	9.289		
0144	8.980	9.010	9.318	9.313	9.421	9.416		
0146	9.103	9.133	9.441	9.436	9.546	9.541		
0148	9.228	9.258	9.566	9.561	9.671	9.666		
0150	9.353	9.383	9.691	9.686	9.796	9.791		
0152	9.478	9.508	9.816	9.811	9.921	9.916		
0154	9.603	9.633	9.941	9.936	10.046	10.041		
0156	9.728	9.758	10.066	10.061	10.171	10.166	+ 0.010	+ 0.000
0158	9.853	9.883	10.191	10.186	10.296	10.291	- 0.000	- 0.020
0160	9.980	10.010	10.318	10.313	10.423	10.418		
0162	10.105	10.135	10.443	10.438	10.548	10.543		
0164	10.230	10.260	10.568	10.563	10.673	10.668		
0166	10.355	10.385	10.693	10.688	10.798	10.793		

Standard E-Seals Series 69

High Flex External Pressure E-Seal Tables

DIAMETER DASH NO.	CAVITY I.D. (E)	SEAL I.D. AVG. (B)	3/32" FREE HEIGHT		1/8" FREE HEIGHT		CAVITY I.D. (E)	SEAL I.D. (B)
			C= F= R MAX=	.108 ± .005 .087 ± .001 .030	.140 ± .005 .118 ± .002 .045	TOLERANCES		
			CAVITY O.D. MIN. (D)	SEAL O.D. AVG. MAX. (A)	CAVITY O.D. MIN. (D)	SEAL O.D. AVG. MAX. (A)		
0016	1.000	1.005	1.329	1.299	***	***		
0017	1.062	1.067	1.391	1.361	***	***		
0018	1.125	1.130	1.454	1.424	***	***		
0019	1.187	1.192	1.516	1.486	***	***		
0020	1.250	1.255	1.579	1.549	***	***		
0021	1.312	1.317	1.641	1.611	***	***		
0022	1.375	1.380	1.704	1.674	1.802	1.772		
0023	1.437	1.442	1.766	1.736	1.864	1.834	+ 0.000	+ 0.008
0024	1.500	1.505	1.829	1.799	1.927	1.897	- 0.002	- 0.000
0025	1.562	1.567	1.891	1.861	1.989	1.959		
0026	1.625	1.630	1.954	1.924	2.052	2.022		
0027	1.687	1.692	2.016	1.986	2.114	2.084		
0028	1.750	1.755	2.079	2.049	2.177	2.147		
0029	1.812	1.817	2.141	2.111	2.239	2.209		
0030	1.875	1.880	2.204	2.174	2.302	2.272		
0031	1.937	1.942	2.266	2.236	2.364	2.334		
0032	2.000	2.005	2.331	2.301	2.429	2.399		
0033	2.062	2.067	2.393	2.363	2.491	2.461		
0034	2.125	2.130	2.456	2.426	2.554	2.524		
0035	2.187	2.192	2.518	2.488	2.616	2.586		
0036	2.250	2.255	2.581	2.551	2.679	2.649		
0037	2.312	2.317	2.643	2.613	2.741	2.711		
0038	2.375	2.380	2.706	2.676	2.804	2.774		
0039	2.437	2.442	2.768	2.738	2.866	2.836		
0040	2.500	2.505	2.831	2.801	2.929	2.899		
0041	2.562	2.567	2.893	2.863	2.991	2.961	+ 0.000	+ 0.006
0042	2.625	2.630	2.956	2.926	3.054	3.024	- 0.003	- 0.000
0043	2.687	2.692	3.018	2.988	3.116	3.086		
0044	2.750	2.755	3.081	3.051	3.179	3.149		
0045	2.812	2.817	3.143	3.113	3.241	3.211		
0046	2.875	2.880	3.206	3.176	3.304	3.274		
0047	2.937	2.942	3.268	3.238	3.366	3.336		
0048	3.000	3.005	3.331	3.301	3.429	3.399		
0049	3.062	3.067	3.393	3.363	3.491	3.461		
0050	3.125	3.130	3.456	3.426	3.554	3.524		
0051	3.187	3.192	3.518	3.488	3.616	3.586		
0052	3.250	3.255	3.583	3.553	3.681	3.651		
0053	3.312	3.317	3.645	3.615	3.743	3.713		
0054	3.375	3.380	3.708	3.678	3.806	3.776		
0055	3.437	3.442	3.770	3.740	3.868	3.838		
0056	3.500	3.505	3.833	3.803	3.931	3.901		
0057	3.562	3.567	3.895	3.865	3.993	3.963		
0058	3.625	3.630	3.958	3.928	4.056	4.026		
0059	3.687	3.692	4.020	3.990	4.118	4.088	+ 0.000	+ 0.008
0060	3.750	3.755	4.083	4.053	4.181	4.151	- 0.004	- 0.000
0061	3.812	3.817	4.145	4.115	4.243	4.213		
0062	3.875	3.880	4.208	4.178	4.306	4.276		
0063	3.937	3.942	4.270	4.240	4.368	4.338		
0064	4.000	4.005	4.333	4.303	4.431	4.401		
0065	4.062	4.067	4.395	4.365	4.493	4.463		
0066	4.125	4.130	4.458	4.428	4.556	4.526		
0067	4.187	4.192	4.520	4.490	4.618	4.588		
0068	4.250	4.255	4.585	4.555	4.683	4.653		
0069	4.312	4.317	4.647	4.617	4.745	4.715		
0070	4.375	4.380	4.710	4.680	4.808	4.778		
0071	4.437	4.442	4.772	4.742	4.870	4.840		
0072	4.500	4.505	4.835	4.805	4.933	4.903		
0073	4.562	4.567	4.897	4.867	4.995	4.965		
0074	4.625	4.630	4.960	4.930	5.058	5.028		
0075	4.687	4.692	5.022	4.992	5.120	5.090		
0076	4.750	4.755	5.085	5.055	5.183	5.153	+ 0.000	+ 0.010
0077	4.812	4.817	5.147	5.117	5.245	5.215	- 0.005	- 0.000
0078	4.875	4.880	5.210	5.180	5.308	5.278		
0079	4.937	4.942	5.272	5.242	5.370	5.340		
0080	5.000	5.005	5.335	5.305	5.433	5.403		
0081	5.062	5.067	5.397	5.367	5.495	5.465		
0082	5.125	5.130	5.460	5.430	5.558	5.528		

Standard E-Seals Series 69

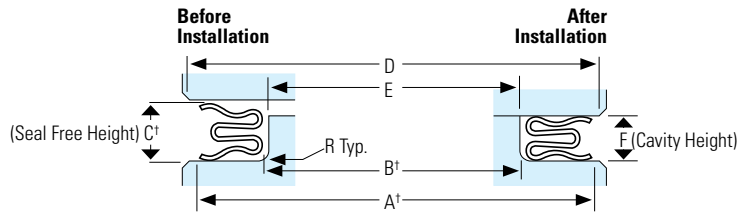

	3/32" FREE HEIGHT	1/8" FREE HEIGHT
C=	.108 ± .005	.140 ± .005
F=	.087 ± .001	.118 ± .002
R MAX=	.030	.045

TOLERANCES

DIAMETER DASH NO.	CAVITY I.D. (E)	SEAL I.D. AVG. (B)	CAVITY O.D. MIN. (D)	SEAL O.D. AVG. MAX. (A)	CAVITY O.D. MIN. (D)	SEAL O.D. AVG. MAX. (A)	CAVITY I.D. (E)	SEAL I.D. (B)
0083	5.187	5.192	5.524	5.494	5.622	5.592		
0084	5.250	5.255	5.587	5.557	5.685	5.655		
0085	5.312	5.317	5.649	5.619	5.747	5.717		
0086	5.375	5.380	5.712	5.682	5.810	5.780		
0087	5.437	5.442	5.774	5.744	5.872	5.842		
0088	5.500	5.505	5.837	5.807	5.935	5.905	+ 0.000	+ 0.012
0089	5.562	5.567	5.899	5.869	5.997	5.967	- 0.006	- 0.000
0090	5.625	5.630	5.962	5.932	6.060	6.030		
0092	5.750	5.755	6.087	6.057	6.185	6.155		
0094	5.875	5.880	6.212	6.182	6.310	6.280		
0096	6.000	6.005	6.337	6.307	6.435	6.405		
0098	6.125	6.130	6.462	6.432	6.560	6.530		
0100	6.250	6.255	6.589	6.559	6.687	6.657		
0102	6.375	6.380	6.714	6.684	6.812	6.782		
0104	6.500	6.505	6.839	6.809	6.937	6.907	+ 0.000	+ 0.014
0106	6.625	6.630	6.964	6.934	7.062	7.032	- 0.007	- 0.000
0108	6.750	6.755	7.089	7.059	7.187	7.157		
0110	6.875	6.880	7.214	7.184	7.312	7.282		
0112	7.000	7.005	7.339	7.309	7.437	7.407		
0114	7.125	7.130	7.464	7.434	7.562	7.532		
0116	7.250	7.255	7.591	7.561	7.689	7.659		
0118	7.375	7.380	7.716	7.686	7.814	7.784		
0120	7.500	7.505	7.841	7.811	7.939	7.909	+ 0.000	+ 0.016
0122	7.625	7.630	7.966	7.936	8.064	8.034	- 0.007	- 0.000
0124	7.750	7.755	8.091	8.061	8.189	8.159		
0126	7.875	7.880	8.216	8.186	8.314	8.284		
0128	8.000	8.005	8.341	8.311	8.439	8.409		
0130	8.125	8.130	8.466	8.436	8.564	8.534		
0132	8.250	8.255	8.593	8.563	8.691	8.661		
0134	8.375	8.380	8.718	8.688	8.816	8.786		
0136	8.500	8.505	8.843	8.813	8.941	8.911	+ 0.000	+ 0.018
0138	8.625	8.630	8.968	8.938	9.066	9.036	- 0.009	- 0.000
0140	8.750	8.755	9.093	9.063	9.191	9.161		
0142	8.875	8.880	9.218	9.188	9.316	9.286		
0144	9.000	9.005	9.343	9.313	9.441	9.411		
0146	9.125	9.130	9.468	9.438	9.566	9.536		
0148	9.250	9.255	9.595	9.565	9.693	9.663		
0150	9.375	9.380	9.720	9.690	9.818	9.788		
0152	9.500	9.505	9.845	9.815	9.943	9.913	+ 0.000	+ 0.020
0154	9.625	9.630	9.970	9.940	10.068	10.038	- 0.010	- 0.000
0156	9.750	9.755	10.095	10.065	10.193	10.163		
0158	9.875	9.880	10.220	10.190	10.318	10.288		
0160	10.000	10.005	10.345	10.315	10.443	10.413		
0162	10.125	10.130	10.470	10.440	10.568	10.538		
0164	10.250	10.255	10.597	10.567	10.695	10.665		
0166	10.375	10.380	10.722	10.692	10.820	10.790		
0168	10.500	10.505	10.847	10.817	10.945	10.915	+ 0.000	+ 0.022
0170	10.625	10.630	10.972	10.942	11.070	11.040	- 0.011	- 0.000
0172	10.750	10.755	11.097	11.067	11.195	11.165		
0174	10.875	10.880	11.222	11.192	11.320	11.290		
0176	11.000	11.005	11.347	11.317	11.445	11.415		
0178	11.125	11.130	11.472	11.442	11.570	11.540		
0180	11.250	11.255	11.599	11.569	11.697	11.667		
0182	11.375	11.380	11.724	11.694	11.822	11.792		
0184	11.500	11.505	11.849	11.819	11.947	11.917	+ 0.000	+ 0.024
0186	11.625	11.630	11.974	11.944	12.072	12.042	- 0.012	- 0.000
0188	11.750	11.755	12.099	12.069	12.197	12.167		
0190	11.875	11.880	12.224	12.194	12.322	12.292		
0192	12.000	12.005	12.349	12.319	12.447	12.417		
0194	12.125	12.130	12.474	12.444	12.572	12.542		
0196	12.250	12.255	12.601	12.571	12.699	12.669		
0198	12.375	12.380	12.726	12.696	12.824	12.794		
0200	12.500	12.505	12.851	12.821	12.949	12.919		
0202	12.625	12.630	12.976	12.946	13.074	13.044	+ 0.000	+ 0.026
0204	12.750	12.755	13.101	13.071	13.199	13.169	- 0.013	- 0.000
0206	12.875	12.880	13.226	13.196	13.324	13.294		
0208	13.000	13.005	13.351	13.321	13.449	13.419		
0210	13.125	13.130	13.476	13.446	13.574	13.544		

Overview of Special 8 Designs

For applications other than the standard E-Seal applications listed and described, Eaton has tabulated the following dimensional, operational, and performance data for eight of the most popular designs. Because these seal cross-sections are used in numerous applications, they are manufactured with well developed and consistent processes. They can therefore be manufactured in a wide range of diameters with shorter lead

times and at lower cost than custom designs.

Table 3B-1, Summary of Cross-Sections, gives a general overview of these eight sections. Based on your application's requirements and dimensional constraints, you will be able to narrow your selection to one or more of the following sections[†]. Once you have done so, proceed to the corresponding Cross-Section Data Sheet which will provide you with further performance data and guidance toward dimensioning your cavity.

TABLE 3B-1

Summary of Cross-Sections

Section Seal Profile	A	B	C	D	E	F	G	H
Min. Radial Cavity Room Required ^{††}	.103 (in.)	.165 (in.)	.214 (in.)	.280 (in.)	.160 (in.)	.210 (in.)	.155 (in.)	.229 (in.)
Axial Deflection Capability ^{†††}	.021 (in.)	.023 (in.)	.025 (in.)	.068 (in.)	.045 (in.)	.051 (in.)	.059 (in.)	.107 (in.)
Axial Spring Rate ^{††††}	1920 (lbs./in./in.Circ)	1820 (lbs./in./in.Circ)	2475 (lbs./in./in.Circ)	95 (lbs./in./in.Circ)	315 (lbs./in./in.Circ)	260 (lbs./in./in.Circ)	450 (lbs./in./in.Circ)	130 (lbs./in./in.Circ)
Leakage Capability ^{†††††}	.50 (SCFM)	.06 (SCFM)	.02 (SCFM)	.10 (SCFM)	.24 (SCFM)	.05 (SCFM)	.12 (SCFM)	.08 (SCFM)
Cross-Section Data Sheet	34	35	36	37	38	39	40	41

[†] Please note: if you have determined that none of the following sections described will meet your needs, please go to the Appendix, where you will find an Application Sheet requesting more information about your application. Please complete and send this form to Eaton for a custom designed seal.

^{††} This is to be used only as a rough selection guide; once section is determined, see page 41, Determining Your Cavity Dimensions.

^{†††} Values shown represent an average max deflection capability before significant permanent deformation of the section occurs. See specific Cross-Section Data Sheet for further details.

^{††††} Values given correspond to a 20" diameter seal made of Inconel 718 and the corresponding axial deflection shown above. Values will vary with seal diameter, material type, etc. Please see corresponding Cross-Section Data Sheet for specific data for your application's requirements.

^{†††††} Values given correspond to a 20" diameter seal made of Inconel 718, the corresponding axial deflection shown above, and sealing air at 1000°F (538°C) with a pressure differential of 80 psi. Sealing surfaces have a 32 RMS circular lay surface finish. Values will vary with seal material type, axial compression, pressure differential, operating temperature, mating cavity surface finish, etc. Please see corresponding Cross-Section Data Sheet for application specific data.

Special 8 E-Seals

Short Leg, Single Convolution Cross-Section "A" Data Sheet

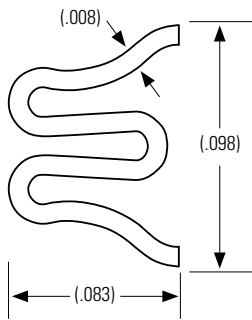

Mechanical Characteristics of the Short Leg, Single Convolution E-Seal

Values on the graphs correspond to seals made of fully heat treated Inconel 718, tested at ambient temperatures, unless otherwise indicated. Leakage test results correspond to a seal pressurized with air at 80 psi.

The following Scaling Factors are to be used as multipliers of the values from the graphs, to customize seal performance to an application's particular conditions. To obtain an approximate force-to-compress (FTC) and leakage (L) values, simply multiply the load and/or leakage obtained from the graphs (FTC₀ and L₀, respectively) by the multipliers below that conform to your requirements.

FORCE SCALING FACTOR

FTC = Force to Compress
(your application's specifications)

SEAL MATERIAL

Inconel X-750 or Waspaloy:
FTC = FTC₀ x 0.83

LEAKAGE SCALING FACTORS

L = Leakage
(your application's specifications)

OPERATING TEMPERATURE

200°F (93°C):	L = L ₀ x 2.65
400°F (204°C):	L = L ₀ x 2.26
600°F (316°C):	L = L ₀ x 1.88
800°F (427°C):	L = L ₀ x 1.38
1000°F (538°C):	L = L ₀ x 1.00
1200°F (649°C):	L = L ₀ x 0.59

PRESSURE DIFFERENTIAL (ΔP) ACROSS SEAL

20 psid:	L = L ₀ x 0.3
40 psid:	L = L ₀ x 0.5
60 psid:	L = L ₀ x 0.8
80 psid:	L = L ₀ x 1.0
100 psid:	L = L ₀ x 1.3
120 psid:	L = L ₀ x 1.5
140 psid:	L = L ₀ x 1.8
150 psid:	L = L ₀ x 1.9

CAVITY SURFACE FINISH

16 μin RMS:	L = L ₀ x 1.00
32 μin RMS:	L = L ₀ x 1.00
64 μin RMS:	L = L ₀ x 1.00

Load (FTC₀) vs. Deflection

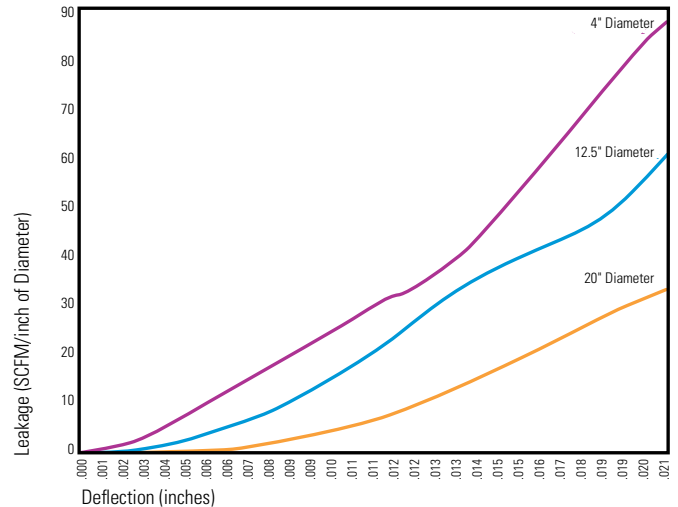

Manufacturable diameter range: 1.5" < Seal O.D. < 40"

Leakage (L₀) vs. Deflection (at 1000°F)

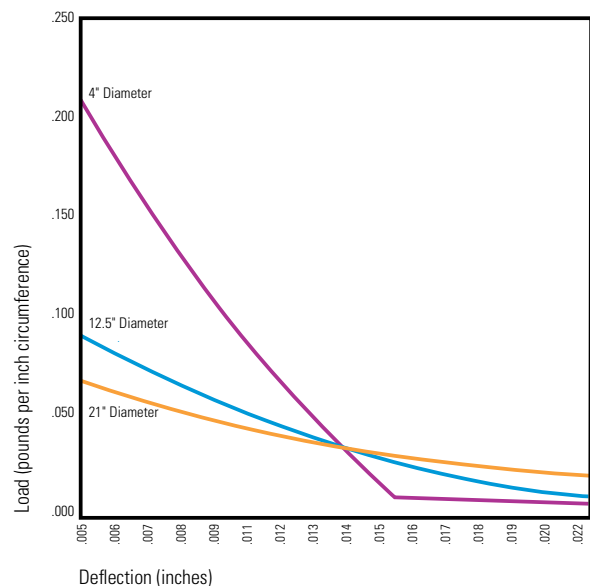

Please see page 41 for instructions on how to determine your cavity

Special 8 E-Seals

Medium Leg, Single Convolution Cross-Section "B" Data Sheet

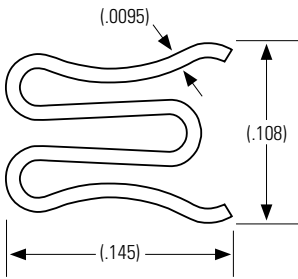

Mechanical Characteristics of the Medium Leg, Single Convolution E-Seal

Values on the graphs correspond to seals made of fully heat treated Inconel 718, tested at ambient temperatures, unless otherwise indicated. Leakage test results correspond to a seal pressurized with air at 80 psi.

The following Scaling Factors are to be used as multipliers of the values from the graphs, to customize seal performance to an application's particular conditions. To obtain your approximate force-to-compress (FTC) and leakage (L) values, simply multiply the load and/or leakage obtained from the graphs (FTC₀ and L₀, respectively) by the multipliers below that conform to your requirements.

FORCE SCALING FACTOR

FTC = Force to Compress
(your application's specifications)

SEAL MATERIAL

Inconel X-750 or Waspaloy:
FTC = FTC₀ x 0.83

LEAKAGE SCALING FACTORS

L = Leakage
(your application's specifications)

OPERATING TEMPERATURE

200°F (93°C):	L = L ₀ x 2.65
400°F (204°C):	L = L ₀ x 2.26
600°F (316°C):	L = L ₀ x 1.88
800°F (427°C):	L = L ₀ x 1.38
1000°F (538°C):	L = L ₀ x 1.00
1200°F (649°C):	L = L ₀ x 0.59

PRESSURE DIFFERENTIAL (ΔP) ACROSS SEAL

20 psid:	L = L ₀ x 0.3
40 psid:	L = L ₀ x 0.5
60 psid:	L = L ₀ x 0.8
80 psid:	L = L ₀ x 1.0
100 psid:	L = L ₀ x 1.2
120 psid:	L = L ₀ x 1.5
140 psid:	L = L ₀ x 1.7
150 psid:	L = L ₀ x 1.8

CAVITY SURFACE FINISH

16 μin RMS:	L = L ₀ x 0.95
32 μin RMS:	L = L ₀ x 1.00
64 μin RMS:	L = L ₀ x 1.10

Load (FTC₀) vs. Deflection

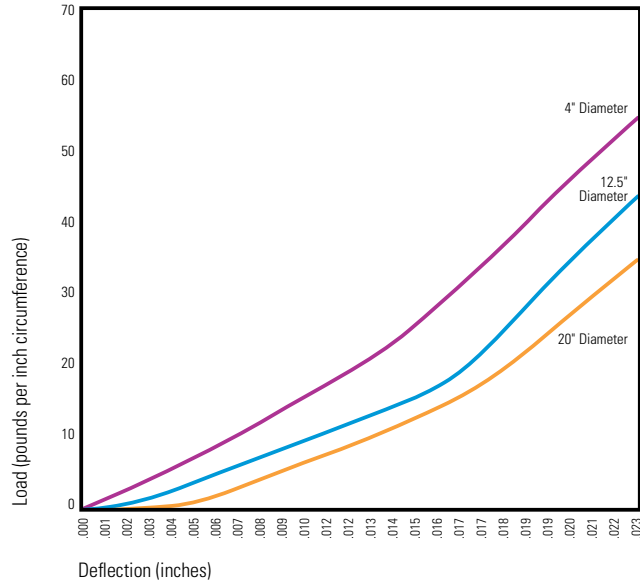

Leakage (L₀) vs. Deflection (at 1000°F)

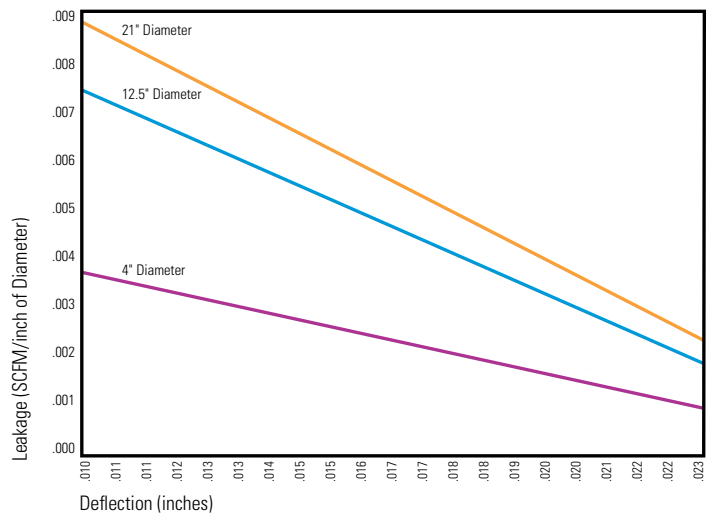

Manufacturable diameter range: 2.6" < Seal O.D. < 40"

Please see page 41 for instructions on how to determine your cavity

Special 8 E-Seals

Long Leg, Single Convolution Cross-Section "C" Data Sheet

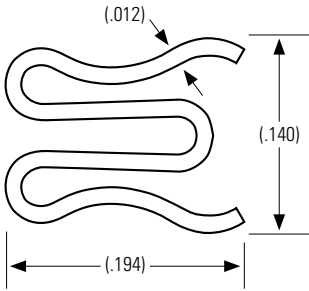

Mechanical Characteristics of the Long Leg, Single Convolution E-Seal

Values on the graphs correspond to seals made of fully heat treated Inconel 718, tested at ambient temperatures, unless otherwise indicated. Leakage test results correspond to a seal pressurized with air at 80 psi.

The following Scaling Factors are to be used as multipliers of the values from the graphs, to customize seal performance to an application's particular conditions. To obtain your approximate force-to-compress (FTC) and leakage (L) values, simply multiply the load and/or leakage obtained from the graphs (FTC₀ and L₀, respectively) by the multipliers below that conform to your requirements.

FORCE SCALING FACTOR

FTC = Force to Compress
(your application's specifications)

SEAL MATERIAL

Inconel X-750 or Waspaloy:
FTC = FTC₀ x 0.83

LEAKAGE SCALING FACTORS

L = Leakage
(your application's specifications)

OPERATING TEMPERATURE

200°F (93°C):	L = L ₀ x 2.65
400°F (204°C):	L = L ₀ x 2.26
600°F (316°C):	L = L ₀ x 1.88
800°F (427°C):	L = L ₀ x 1.38
1000°F (538°C):	L = L ₀ x 1.00
1200°F (649°C):	L = L ₀ x 0.59

PRESSURE DIFFERENTIAL (ΔP) ACROSS SEAL

20 psid:	L = L ₀ x 0.2
40 psid:	L = L ₀ x 0.4
60 psid:	L = L ₀ x 0.7
80 psid:	L = L ₀ x 1.0
100 psid:	L = L ₀ x 1.5
120 psid:	L = L ₀ x 2.0
140 psid:	L = L ₀ x 2.6
150 psid:	L = L ₀ x 3.0

CAVITY SURFACE FINISH

16 μin RMS:	L = L ₀ x 1.00
32 μin RMS:	L = L ₀ x 1.00
64 μin RMS:	L = L ₀ x 1.10

Load (FTC₀) vs. Deflection

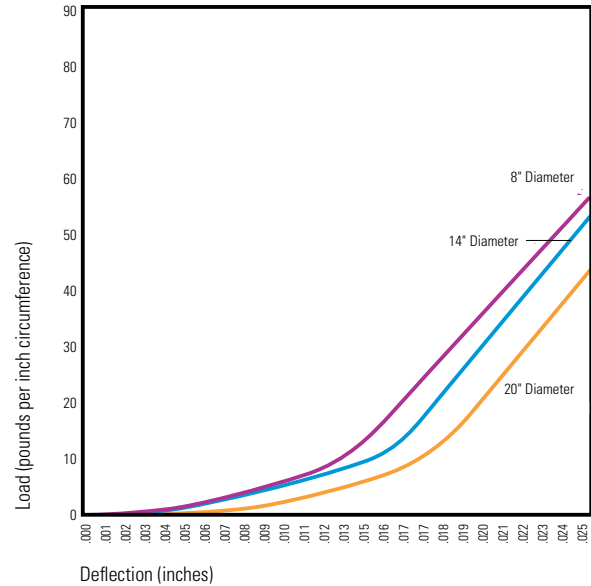

Leakage (L₀) vs. Deflection (at 1000°F)

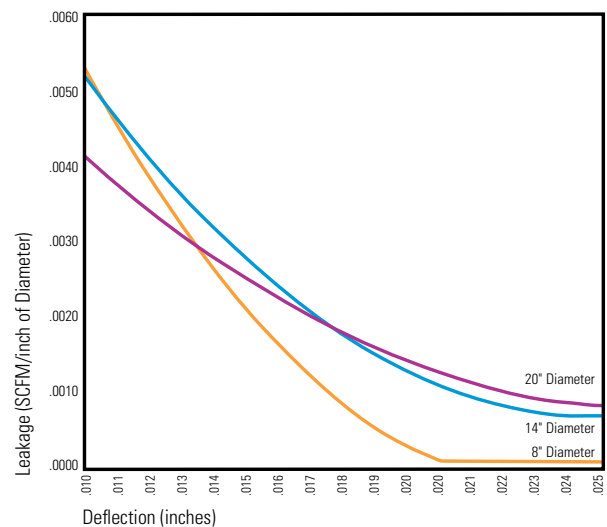

Manufacturable diameter range: 1.6" < Seal O.D. < 40"

Please see page 41 for instructions on how to determine your cavity

Special 8 E-Seals

Extra-Long Leg, Single Convolution Cross-Section "D" Data Sheet

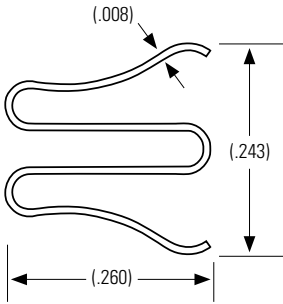

Mechanical Characteristics of the Extra-Long Leg, Single Convolution E-Seal

Values on the graphs correspond to seals made of fully heat treated Inconel 718, tested at ambient temperatures, unless otherwise indicated. Leakage test results correspond to a seal pressurized with air at 80 psi.

The following Scaling Factors are to be used as multipliers of the values from the graphs, to customize seal performance to an application's particular conditions. To obtain your approximate force-to-compress (FTC) and leakage (L) values, simply multiply the load and/or leakage obtained from the graphs (FTC₀ and L₀, respectively) by the multipliers below that conform to your requirements.

FORCE SCALING FACTOR

FTC = Force to Compress
(your application's specifications)

SEAL MATERIAL

Inconel X-750 or Waspaloy:
FTC = FTC₀ x 0.83

LEAKAGE SCALING FACTORS

L = Leakage
(your application's specifications)

OPERATING TEMPERATURE

200°F (93°C): L = L₀ x 2.65
400°F (204°C): L = L₀ x 2.26
600°F (316°C): L = L₀ x 1.88
800°F (427°C): L = L₀ x 1.38
1000°F (538°C): L = L₀ x 1.00
1200°F (649°C): L = L₀ x 0.59

PRESSURE DIFFERENTIAL (ΔP) ACROSS SEAL

20 psid: L = L₀ x 0.3
40 psid: L = L₀ x 0.5
60 psid: L = L₀ x 0.8
80 psid: L = L₀ x 1.0
100 psid: L = L₀ x 1.2
120 psid: L = L₀ x 1.5
140 psid: L = L₀ x 1.7
150 psid: L = L₀ x 1.9

CAVITY SURFACE FINISH

16 μin RMS: L = L₀ x 0.95
32 μin RMS: L = L₀ x 1.00
64 μin RMS: L = L₀ x 1.10

Load (FTC₀) vs. Deflection

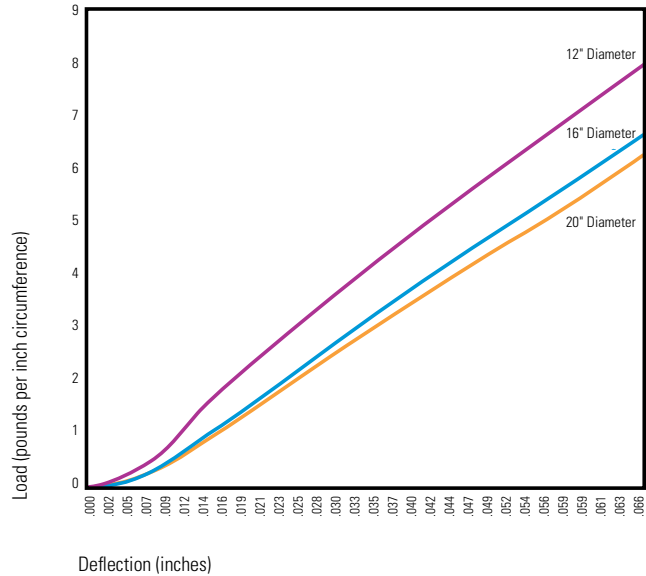

Leakage (L₀) vs. Deflection (at 1000°F)

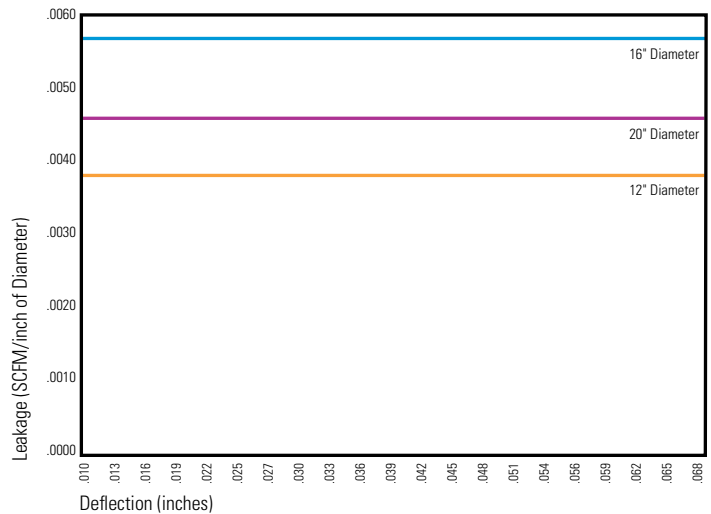

Manufacturable diameter range: 5" < Seal O.D. < 40"

Please see page 41 for instructions on how to determine your cavity

Special 8 E-Seals

Short Leg, Double Convolution Cross-Section "E" Data Sheet

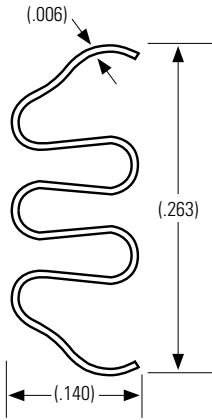

Mechanical Characteristics of the Short Leg, Double Convolution E-Seal

Values on the graphs correspond to seals made of fully heat treated Inconel 718, tested at ambient temperatures, unless otherwise indicated. Leakage test results correspond to a seal pressurized with air at 80 psi.

The following Scaling Factors are to be used as multipliers of the values from the graphs, to customize seal performance to an application's particular conditions. To obtain your approximate force-to-compress (FTC) and leakage (L) values, simply multiply the load and/or leakage obtained from the graphs (FTC₀ and L₀, respectively) by the multipliers below that conform to your requirements.

FORCE SCALING FACTOR

FTC = Force to Compress
(your application's specifications)

SEAL MATERIAL

Inconel X-750 or Waspaloy:
FTC = FTC₀ x 0.83

LEAKAGE SCALING FACTORS

L = Leakage
(your application's specifications)

OPERATING TEMPERATURE

200°F (93°C):	L = L ₀ x 2.65
400°F (204°C):	L = L ₀ x 2.26
600°F (316°C):	L = L ₀ x 1.88
800°F (427°C):	L = L ₀ x 1.38
1000°F (538°C):	L = L ₀ x 1.00
1200°F (649°C):	L = L ₀ x 0.59

PRESSURE DIFFERENTIAL (ΔP) ACROSS SEAL

20 psid:	L = L ₀ x 0.3
40 psid:	L = L ₀ x 0.6
60 psid:	L = L ₀ x 0.8
80 psid:	L = L ₀ x 1.0
100 psid:	L = L ₀ x 1.2
120 psid:	L = L ₀ x 1.5
140 psid:	L = L ₀ x 1.7
150 psid:	L = L ₀ x 1.8

CAVITY SURFACE FINISH

16 μin RMS:	L = L ₀ x 1.00
32 μin RMS:	L = L ₀ x 1.00
64 μin RMS:	L = L ₀ x 1.00

Load (FTC₀) vs. Deflection

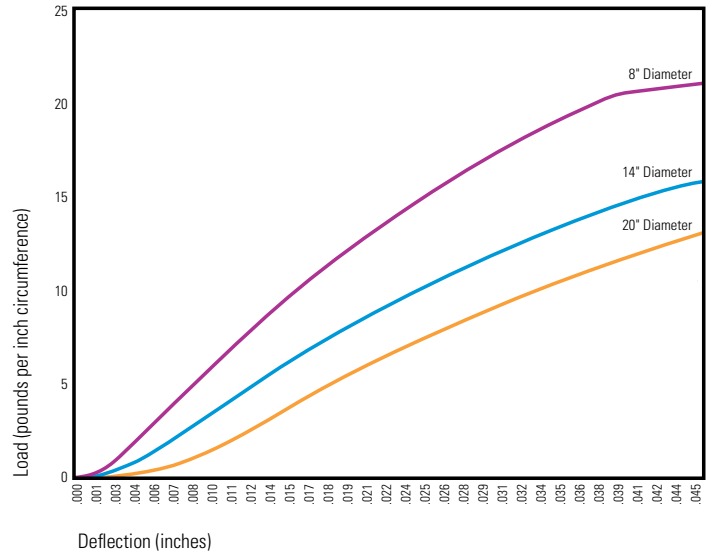

Leakage (L₀) vs. Deflection (at 1000°F)

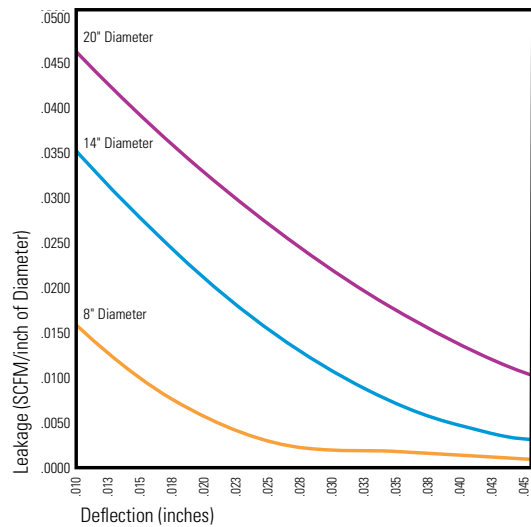

Manufacturable diameter range: 4" < Seal O.D. < 40"

Please see page 41 for instructions on how to determine your cavity

Special 8 E-Seals

Long Leg, Double Convolution Cross-Section "F" Data Sheet

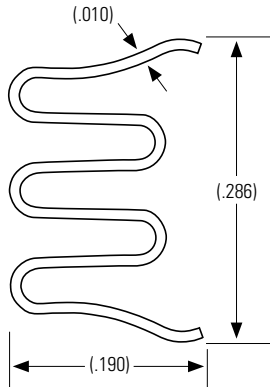

Mechanical Characteristics of the Long Leg, Double Convolution E-Seal

Values on the graphs correspond to seals made of fully heat treated Inconel 718, tested at ambient temperatures, unless otherwise indicated. Leakage test results correspond to a seal pressurized with air at 80 psi.

The following Scaling Factors are to be used as multipliers of the values from the graphs, to customize seal performance to an application's particular conditions. To obtain your approximate force-to-compress (FTC) and leakage (L) values, simply multiply the load and/or leakage obtained from the graphs (FTC₀ and L₀, respectively) by the multipliers below that conform to your requirements.

FORCE SCALING FACTOR

FTC = Force to Compress
(your application's specifications)

SEAL MATERIAL

Inconel X-750 or Waspaloy:
FTC = FTC₀ x 0.83

LEAKAGE SCALING FACTORS

L = Leakage
(your application's specifications)

OPERATING TEMPERATURE

200°F (93°C): L = L₀ x 2.65
400°F (204°C): L = L₀ x 2.26
600°F (316°C): L = L₀ x 1.88
800°F (427°C): L = L₀ x 1.38
1000°F (538°C): L = L₀ x 1.00
1200°F (649°C): L = L₀ x 0.59

PRESSURE DIFFERENTIAL (ΔP) ACROSS SEAL

20 psid: L = L₀ x 0.5
40 psid: L = L₀ x 0.6
60 psid: L = L₀ x 0.8
80 psid: L = L₀ x 1.0
100 psid: L = L₀ x 1.2
120 psid: L = L₀ x 1.4
140 psid: L = L₀ x 1.7
150 psid: L = L₀ x 1.8

CAVITY SURFACE FINISH

16 μin RMS: L = L₀ x 0.98
32 μin RMS: L = L₀ x 1.00
64 μin RMS: L = L₀ x 1.10

Load (FTC₀) vs. Deflection

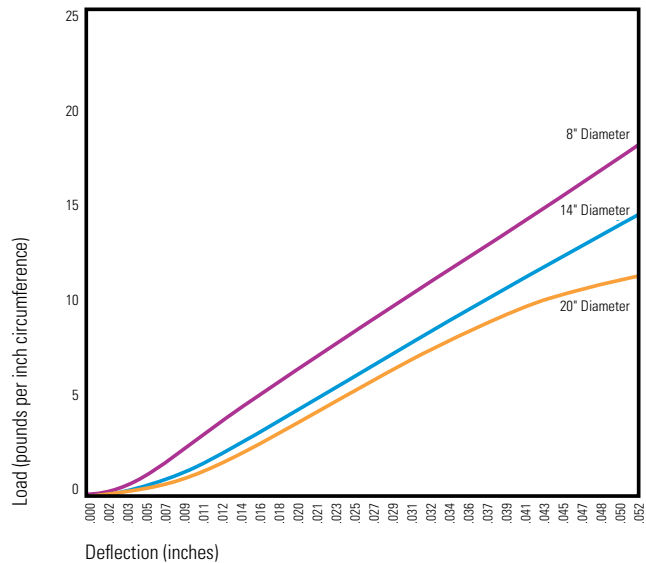

Leakage (L₀) vs. Deflection (at 1000°F)

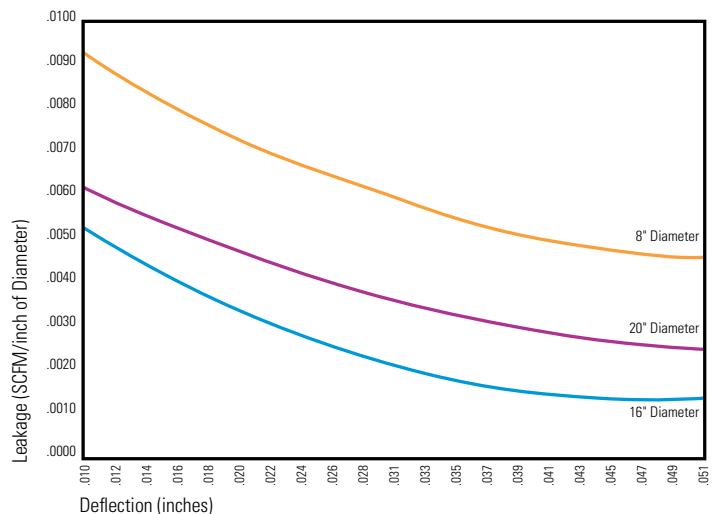

Manufacturable diameter range: 5" < Seal O.D. < 40"

Please see page 41 for instructions on how to determine your cavity

Special 8 E-Seals

Short Leg, Quadruple Convolution Cross-Section "G" Data Sheet

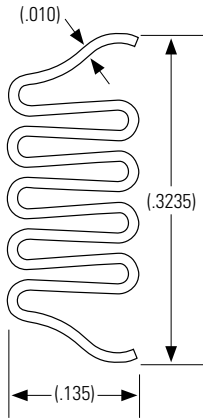

Mechanical Characteristics of the Short Leg, Quadruple Convolution E-Seal

Values on the graphs correspond to seals made of fully heat treated Inconel 718, tested at ambient temperatures, unless otherwise indicated. Leakage test results correspond to a seal pressurized with air at 80 psi.

The following Scaling Factors are to be used as multipliers of the values from the graphs, to customize seal performance to an application's particular conditions. To obtain your approximate force-to-compress (FTC) and leakage (L) values, simply multiply the load and/or leakage obtained from the graphs (FTC₀ and L₀, respectively) by the multipliers below that conform to your requirements.

FORCE SCALING FACTOR

FTC = Force to Compress
(your application's specifications)

SEAL MATERIAL

Inconel X-750 or Waspaloy:
FTC = FTC₀ x 0.83

LEAKAGE SCALING FACTORS

L = Leakage
(your application's specifications)

OPERATING TEMPERATURE

200°F (93°C): L = L₀ x 2.65
400°F (204°C): L = L₀ x 2.26
600°F (316°C): L = L₀ x 1.88
800°F (427°C): L = L₀ x 1.38
1000°F (538°C): L = L₀ x 1.00
1200°F (649°C): L = L₀ x 0.59

PRESSURE DIFFERENTIAL (ΔP) ACROSS SEAL

20 psid: L = L₀ x 0.3
40 psid: L = L₀ x 0.5
60 psid: L = L₀ x 0.8
80 psid: L = L₀ x 1.0
100 psid: L = L₀ x 1.2
120 psid: L = L₀ x 1.5
140 psid: L = L₀ x 1.7
150 psid: L = L₀ x 1.9

CAVITY SURFACE FINISH

16 μin RMS: L = L₀ x 0.98
32 μin RMS: L = L₀ x 1.00
64 μin RMS: L = L₀ x 1.10

Load (FTC₀) vs. Deflection

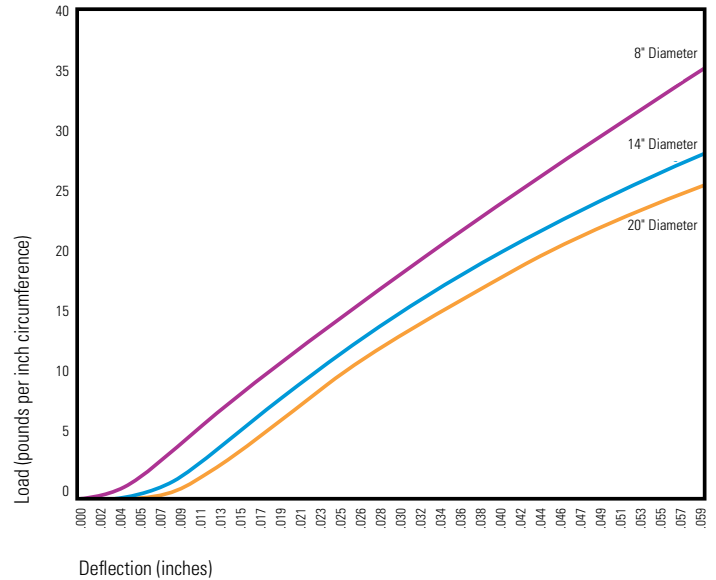

Leakage (L₀) vs. Deflection (at 1000°F)

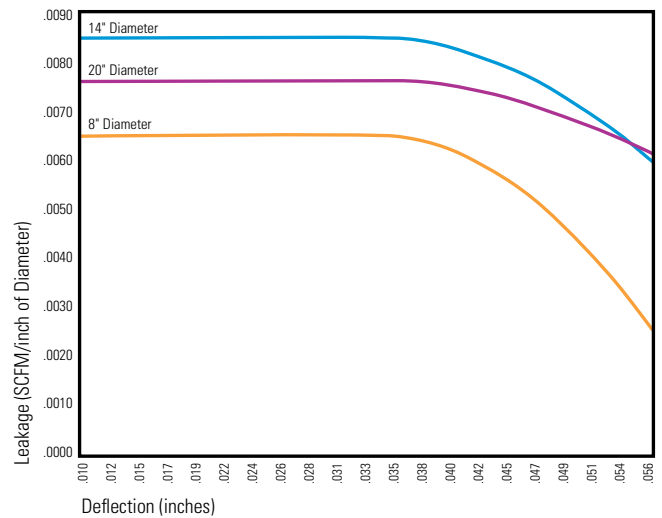

Manufacturable diameter range: 7" < Seal O.D. < 40"

Please see page 41 for instructions on how to determine your cavity

Special 8 E-Seals

Long Leg, Quadruple Convolution Cross-Section "H" Data Sheet

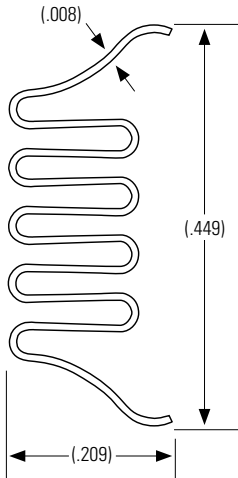

Mechanical Characteristics of the Long Leg, Quadruple Convolution E-Seal

Values on the graphs correspond to seals made of fully heat treated Inconel 718, tested at ambient temperatures, unless otherwise indicated. Leakage test results correspond to a seal pressurized with air at 80 psi.

The following Scaling Factors are to be used as multipliers of the values from the graphs, to customize seal performance to an application's particular conditions. To obtain your approximate force-to-compress (FTC) and leakage (L) values, simply multiply the load and/or leakage obtained from the graphs (FTC₀ and L₀, respectively) by the multipliers below that conform to your requirements.

FORCE SCALING FACTOR

FTC = Force to Compress
(your application's specifications)

SEAL MATERIAL

Inconel X-750 or Waspaloy:
FTC = FTC₀ x 0.83

LEAKAGE SCALING FACTORS

L = Leakage
(your application's specifications)

OPERATING TEMPERATURE

200°F (93°C): L = L₀ x 2.65
400°F (204°C): L = L₀ x 2.26
600°F (316°C): L = L₀ x 1.88
800°F (427°C): L = L₀ x 1.38
1000°F (538°C): L = L₀ x 1.00
1200°F (649°C): L = L₀ x 0.59

PRESSURE DIFFERENTIAL (ΔP) ACROSS SEAL

20 psid: L = L₀ x 0.3
40 psid: L = L₀ x 0.5
60 psid: L = L₀ x 0.8
80 psid: L = L₀ x 1.0
100 psid: L = L₀ x 1.2
120 psid: L = L₀ x 1.5
140 psid: L = L₀ x 1.7
150 psid: L = L₀ x 1.9

CAVITY SURFACE FINISH

16 μin RMS: L = L₀ x 1.00
32 μin RMS: L = L₀ x 1.00
64 μin RMS: L = L₀ x 1.00

Load (FTC₀) vs. Deflection

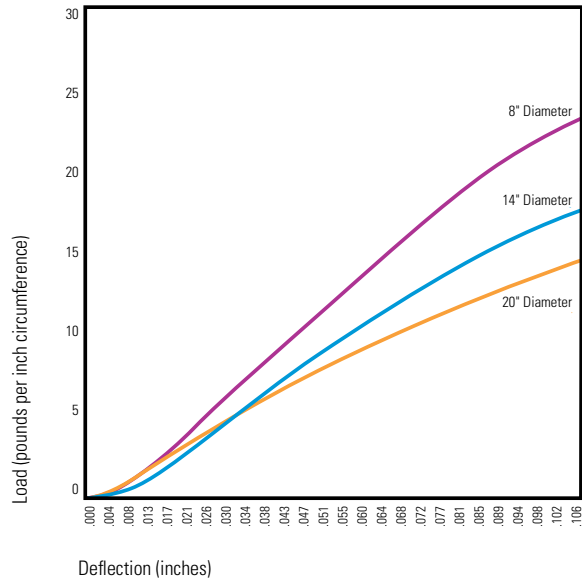

Leakage (L₀) vs. Deflection (at 1000°F)

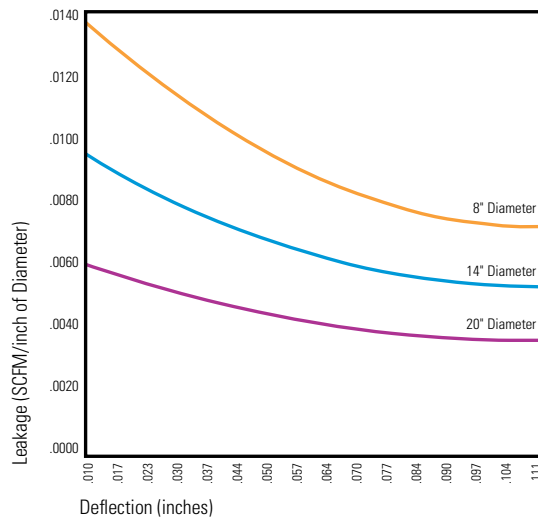

Manufacturable diameter range: 7" < Seal O.D. < 40"

Please see page 41 for instructions on how to determine your cavity

Special 8 E-Seals

Determining Your Cavity Dimensions

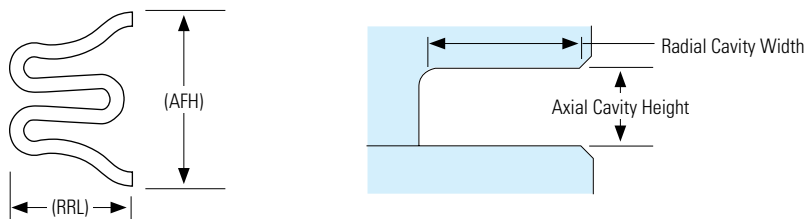

In designing a cavity, the most critical dimensions to determine are the radial and axial heights. To get a good idea of what these dimensions should be (to provide adequate room for the selected cross-section), several factors must be considered:

Radial Cavity Width Determination

- R1.** From the data sheet of the cross-section you have selected, enter the radial leg length (RRL)
- R2.** Calculate the relative thermal growth differential between the seal and cavity. Use the basic $\alpha\Delta T$ equation for the seal, based on the following thermal expansion coefficients (α) for Inconel 718 and Waspaloy:

Temperature	α Inconel 718 ($\times 10^{-6}$ in/in $^{\circ}$)	α Waspaloy ($\times 10^{-6}$ in/in $^{\circ}$)
200°F (93°C)	7.15	6.80
400°F (204°C)	7.40	7.23
600°F (316°C)	7.70	7.50
800°F (427°C)	7.80	7.70
1000°F (538°C)	8.10	7.90
1200°F (649°C)	8.35	8.10

- Enter calculated seal thermal growth (for approximate outer seal diameter)
- R3.** Enter cavity Outer Diameter thermal growth (for approximate outer cavity diameter)
- R4.** Enter cavity Inner Diameter thermal growth (for approximate inner cavity diameter)
- R5.** Subtract the value of **R3** from **R2** and enter here (if <0, enter 0)
- R6.** Subtract the value of **R2** from **R4** and enter here (if < 0, enter 0)
- R7.** Add the values of **R5** and **R6**. This is the total relative thermal growth differential
- R8.** Divide the value of **R7** by 2 and enter result here
- R9.** Add the values of **R1** and **R8**. This is the **approximate minimum radial cavity width required** for the selected cross-section:

R1.

R2.

R3.

R4.

R5.

R6.

R7.

R8.

R9. †

† Please note, this is an approximation only and does not account for cavity corner radii, edge-breaks, chamfers, etc.

Axial Cavity Height Determination

- A1.** From the data sheet of the cross-section you have selected, enter the axial free height (AFH)
- A2.** Enter the total manufacturing tolerance of the axial cavity height
- A3.** Enter the amount of cavity axial opening during operation; cavity opens by (enter as a positive value; if zero, enter 0)
- A4.** Enter the amount of cavity axial closure during operation; cavity closes by (enter as a positive number; if zero, enter 0)
- A5.** Subtract .010 from the value entered in **A1**
- A6.** Subtract the value entered in **A3** from the value of **A5**. This is the **maximum recommended axial cavity height**:

A1.

A2.

A3.

A4.

A5.

A6.

Maximum Compression Check

The following calculations are recommended to avoid possible over-compression of the selected cross-section:

- C1.** Enter the value entered for **A5** from above
- C2.** Subtract the value entered in **A2** from **C1**. This is the minimum cold cavity axial height
- C3.** Subtract the value entered in **A4** from **C2**. This is the minimum hot cavity axial height
- C4.** Add .005 to the value of **A1**
- C5.** Subtract the value of **C3** from the value of **C4**. This is the **maximum compression of the seal**

C1.

C2.

C3.

C4.

C5.

Compare the value calculated in **C5** to the maximum recommended seal compression for the cross-section selected. See the *Load vs. Deflection* graph on the corresponding Cross-Section Data Sheet. If the value calculated in **C5** is greater than the recommended maximum compression, please contact Eaton for further consultation.

The above calculations are to be used as a rough guide only. For complete seal design, fill out the *Application Sheet* provided in the **Appendix** and fax to Eaton at (301) 902-3602.

U-Plex

U-Plex Seal Description

(U.S. PAT NO. 5630593)

FIGURE 4-1

Springback

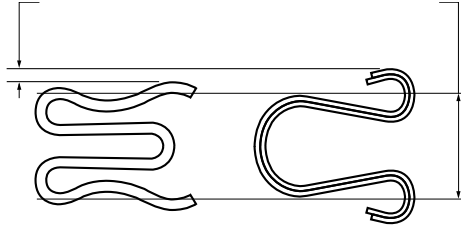
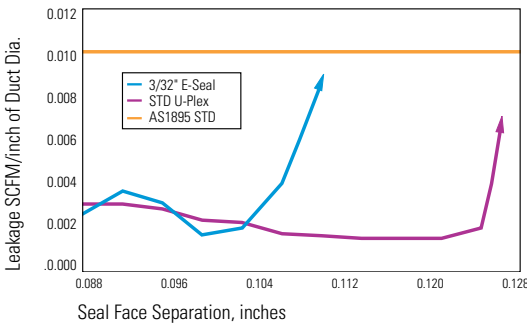
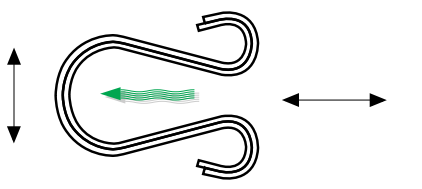

FIGURE 4-2

Axial and Radial Deflections



The U-Plex seal is characterized by the following Performance Capabilities:

- Extremely flexible—designed to operate in the Elastic Range
- Reusable
- Offers as much as 2.5 to 5 times the deflection capability of the Standard E-Seal
- Relaxed flange flatness allows up to .018" per linear circumference duct diameter
- Less wear of the flange sealing faces
- Leakage rates comparable to those of the E-Seal

Exceptions to this would occur with exposure to elevated temperatures for prolonged time, i.e. stress-relaxation effects.

The U-Plex seal is Eaton's most flexible cross-section. It is composed of two plies of thinner material. These plies act independently when the seal is compressed (like a multi-leaf spring) yet act as one in containing pressure. These plies give it remarkable load and deflection characteristics, i.e. extremely low load coupled with extremely high deflection capability, while at the same time maintaining great hoop strength to resist high pressures.

The reasoning behind this technology is simple—decreased moment of inertia in the axial direction (direction of compression), with no effect on moment

of inertia in the radial direction (direction in which pressure acts).

Typical Applications and Locations

The U-Plex seal is suitable for any location requiring excessive axial deflection capability and local compliance ability.

Pressure Capabilities

The U-Plex seal's pressure capabilities are similar to those of the Standard E-Seal. See E-Seal section, page 20 under *Pressure Capabilities* for further details.

Leakage Capability

The leakage capability of the U-Plex seal is essentially equivalent to that of a Standard E-Seal, up to a fixed amount of cavity face separation. However, as cavity face separation increases, the U-Plex seal leakage remains constant, even up to .007" above the seal's unrestrained free height.

As with all Eaton Seals, the sealing line is radiused, and as such provides a line, rather than area, contact. As with the E-Seal, plating is not applied to the U-Plex Seal since the loads generated by it during compression are not high enough for effective smearing of the plating into cavity imperfections.

Diagram depicts an open cavity configuration; seals work equally well in a closed cavity configuration with the same envelope dimensions.

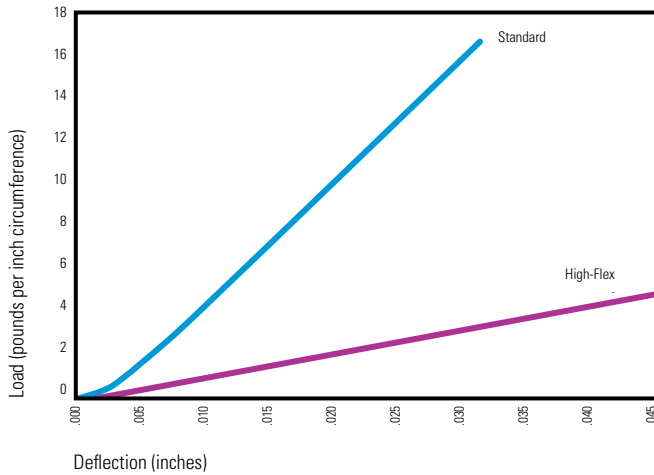

Deflection Capability

In addition to having axial deflection capabilities in excess of the Standard E-Seal, the U-Plex seal exhibits a great resiliency in the compression plane of the seal. For this reason, it has an excellent ability to conform to severely out-of-flat flanges. This feature reduces, and in some cases may even eliminate, the rework and/or replacement of improperly welded flanges, or excessive weld distortion caused by normal welding of large diameter flanges. The graph below demonstrates the U-Plex seals' low load/high deflection capabilities.

Standard Part Number Selection

This catalog offers two U-Plex cross-sections, the Standard U-Plex, and the High-Flex U-Plex. The Standard U-Plex supersedes the Standard Duct E-Seal part numbers as listed in its corresponding table. This section has passed qualification testing per AS1895/23.

The High-Flex U-Plex cross-section is a larger version of the Standard and supersedes the High-Flex Duct E-Seals as listed in its table.

Cavity and seal details are provided on the following page. Please note that we can also manufacture "in-between" sizes as necessary, as well as larger sizes. Please consult Eaton as needed for your application.

TABLE 4-1

Deflection Capability

Duct Outer Diameter	U-Plex Deformation Capability
1.50" to 3.50"	.011" per inch circumference
>3.50"	.018" per inch circumference

High-Flex U-Plex Seal Cross-Section

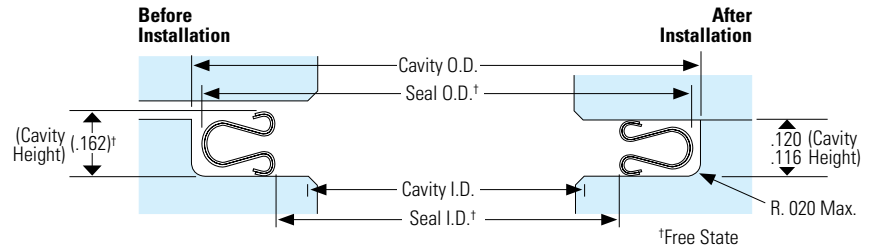
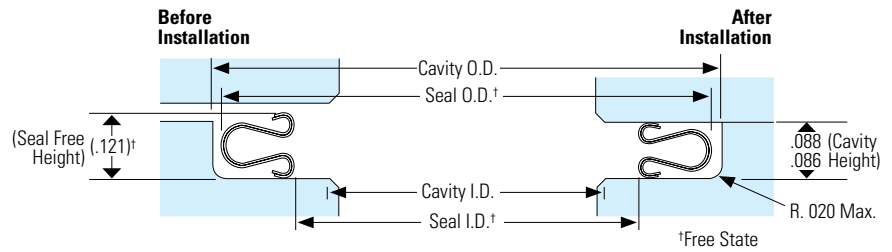

Diagram depicts an open cavity configuration; seals work equally well in a closed cavity configuration with the same envelope dimensions.

PART NO. FOR ORDERING	CAVITY I.D. MAX.	CAVITY O.D. SEAL O.D. AVG. MAX.	CAVITY O.D. TOLERANCE	SUPERSEDES PRESSURESCIENCE™ E-SEAL PART NUMBER	
13315-125	1.236	1.614	1.613	0856	
13315-150	1.486	1.864	1.863	+ 0.002	0857
13315-175	1.736	2.114	2.113	- 0.000	0864
13315-200	1.986	2.364	2.363		0858
13315-225	2.236	2.615	2.614		0865
13315-250	2.486	2.865	2.864	+ 0.003	0859
13315-275	2.736	3.115	3.114	- 0.000	0938
13315-300	2.986	3.365	3.364		0860
13315-325	3.236	3.615	3.614		0867
13315-350	3.486	3.866	3.865		0861
13315-400	3.986	4.366	4.365	+ 0.004	0862
13315-450	4.486	4.866	4.865	- 0.000	0863
13315-500	4.986	5.368	5.367		0868
13315-550	5.486	5.868	5.867	+ 0.006	0869
13315-600	5.986	6.368	6.367	- 0.000	0805
13315-650	6.486	6.868	6.867		2802

U-Plex

Standard U-Plex Seal Cross-Section



Standard U-Plex Cross-Sections Qualification Tested per AS1895/23

PART NO. FOR ORDERING	CAVITY I.D. MAX.	CAVITY O.D. + .005/- .000	SEAL O.D. AVG. MAX.	SUPERSEDES PRESSURESCIENCE™ E-SEAL PART NUMBER
13100-100	0.900	1.250	1.249	3475
13227-100	0.925	1.368	1.365	7387-100
13100-125	1.150	1.500	1.499	3478
13227-125	1.175	1.618	1.615	7387-125
13100-150	1.400	1.750	1.749	0944
13227-150	1.425	1.868	1.865	7387-150
13226-150	1.623	1.945	1.944	8757-150
13100-175	1.695	2.000	1.999	3624
13227-175	1.675	2.118	2.115	7387-175
13226-175	1.888	2.200	2.199	8757-175
13100-200	1.900	2.250	2.249	0945
13227-200	1.925	2.368	2.365	7387-200
13226-200	2.131	2.445	2.444	8757-200
13100-225	2.150	2.500	2.499	3505
13227-225	2.175	2.618	2.615	7387-225
13100-250	2.400	2.750	2.749	0946
13227-250	2.425	2.868	2.865	7387-250
13226-250	2.631	2.945	2.944	8757-250
13100-275	2.650	3.000	2.999	2873-275
13227-275	2.675	3.118	3.115	7387-275
13100-300	2.900	3.250	3.249	2873-300
13227-300	2.925	3.368	3.365	7387-300
13226-300	3.119	3.435	3.434	8757-300
13100-325	3.150	3.500	3.499	2873-325
13227-325	3.175	3.618	3.615	7387-325
13100-350	3.400	3.750	3.749	2873-350
13227-350	3.425	3.868	3.865	7387-350
13226-350	3.619	3.935	3.934	8757-350
13100-400	3.900	4.250	4.249	2873-400
13227-400	3.925	4.368	4.365	7387-400
13226-400	4.117	4.435	4.434	8757-400
13100-450	4.400	4.750	4.749	2873-450
13227-450	4.425	4.868	4.865	7387-450
13226-450	4.617	4.935	4.934	8757-450
13100-500	4.900	5.250	5.249	2873-500
13227-500	4.925	5.368	5.365	7387-500
13226-500	5.115	5.435	5.434	8757-500
13100-550	5.400	5.750	5.749	2873-550
13227-550	5.425	5.868	5.865	7387-550
13226-550	5.614	5.935	5.934	8757-550
13100-600	5.900	6.250	6.249	2873-600
13227-600	5.925	6.368	6.365	7387-600
13226-600	6.113	6.435	6.434	8757-600
13100-650	6.390	6.750	6.749	2873-650
13226-650	6.613	6.935	6.934	8757-650
13100-700	6.880	7.250	7.249	2873-700
13226-700	7.113	7.435	7.434	8757-700
13100-750	7.370	7.750	7.749	2873-750
13226-750	7.613	7.935	7.934	8757-750
13100-800	7.860	8.250	8.249	2873-800
13226-800	8.113	8.435	8.434	8757-800
13100-900	8.840	9.250	9.249	2873-900
13100-1000	9.820	10.250	10.249	2873-1000

Microplex Seals

Static Applications

The Microplex Seal is a specially engineered formed metal seal, designed for low and high pressure extremes at reduced flange loadings.

An important advantage of the Microplex Seal is that it is less sensitive to thermal expansion of the flange joint as compared with C-Seals, and the Microplex Seal can be installed in simpler cavity designs.

The Microplex Seal is ideal for many uses where the capabilities of the costlier E-Seal are not required.

Microplex Seals are high performance, pressure-energized metal seals for applications requiring resistance to temperature and pressure extremes, resistance to corrosive fluids, zero leakage and exceptionally long life, with economy.

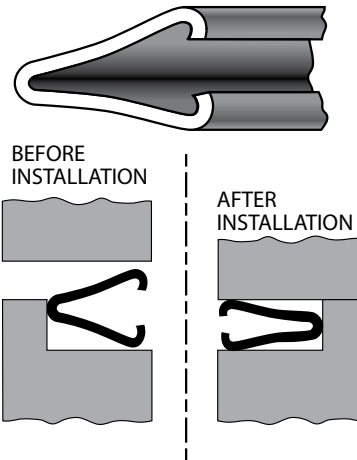

More Seals

Radial Type Seals

The Twist-Flex Seal

(U.S. PAT. NO. 4457523; G.B. PAT. NO. 2129505; FR. PAT. NO. 8316060)

General Characteristics

- Manufacturable diameter range: $3" \leq \text{Seal I.D.} \leq 10"$
- Interference fit on diameters
- Accommodates large axial cavity deflections by sliding
- Low stresses—seal accommodates radial cavity deflections by twisting and rotating, rather than bending
- Suitable for applications up to $+1600^{\circ}\text{F}$ ($+871^{\circ}\text{C}$) (pressure capability dependent upon diameter)

FIGURE 5-1

Twist-Flex Seal Typical Cavity

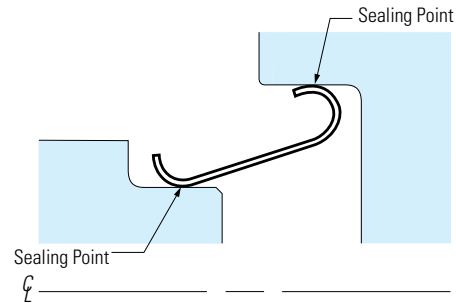

The Wave-Seal

(U.S. PAT. NO. 5799954)

General Characteristics

- Manufacturable diameter range: $8" \leq \text{Seal I.D.} \leq 54"$
- Interference fit on diameters
- Accommodates large axial cavity deflections by sliding
- Low stresses—seal accommodates radial cavity deflections by flexure and rotation about sealing line centers
- Suitable for applications up to $+1600^{\circ}\text{F}$ ($+871^{\circ}\text{C}$) (pressure capability dependent upon diameter)

FIGURE 5-2

Wave-Seal Typical Cavity

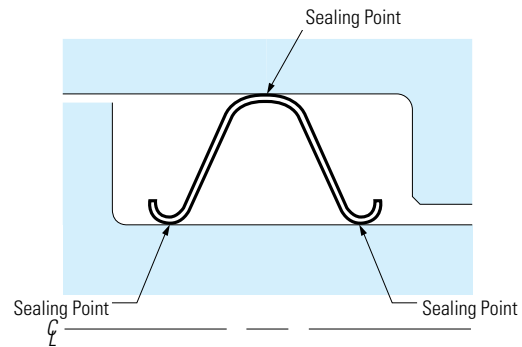

For more information on these seals, please refer to the **Appendix** where you will find an Application Sheet. Simply fill out your application's details and fax it to Eaton.

More Seals

More Seal Characteristics, Shapes, and Installation Options

Seal Characteristics and Features

1. **Out-of-Roundness.** Typical of all circular seals is the out-of-roundness characteristic. Please note, in our tabulated diameter lists, the seal diameters are indicated as average. This averaged value accounts for the seal's out-of-roundness. For example, when you see a MAX.AVG. dimension on a drawing or in the catalog, this indicates that a PI tape will be used to inspect this diameter, and the maximum reading observed is measured. Therefore, at any one diameter measurement across the seal, a diameter reading greater than this MAX. AVG. O.D. may be obtained. The difference between the MAX. AVG. and any maximum reading across the seal is specified as the out-of-roundness.
2. **Out-of-Roundness Snap Fit.** A natural characteristic of round objects, the out-of-roundness can be adjusted to create what is called a "snap-fit" into the cavity (for diameters less than 7"). A seal having this feature will remain in its cavity, once installed, regardless of cavity orientation. This is especially useful for

blind or overhead installations, where the natural tendency of the seal would be to fall out.

3. **Assembly Foolproof.** Due to their symmetry, all of our face-type seals can be installed in any direction.

Seal Shape and Installation Options

1. **Non-Circular Seals.** Eaton is committed to solving sealing needs, regardless of shape or size. Racetrack, triangular, trapezoidal, and teardrop are just a few of the many shapes that Eaton has successfully manufactured in a variety of cross-sections. **Figure 5-3** shows a few of these non-circular shapes.
2. **Split Seals, Sections.** Eaton can further customize seal designs by splitting seals for installation and/or operational purposes. Also Eaton manufactures sections such as semi-circles, arcs, L-shapes, etc. for those non-circular sealing applications. For non-circular sealing application, or requirement of a split seal or section, simply fill out the Application Sheet provided in the **Appendix** to provide Eaton with the information necessary to custom design a seal.

3. **Customized Seals.** In addition to all the cross-sections mentioned in this catalog, Eaton can completely customize a seal to meet any application's requirements by creating new, application-specific designs. This could include adding convolutions, increasing or decreasing material thickness as required, or altering material types, etc.

FIGURE 5-3

Non-circular Seal Shapes



SI Conversion Factors

Measure	Force	Length	Pressure	Surface Finish	Temperature	Volume
To convert from:	lbs./in. Circ	Inches (in.)	Lbf/in ² (psi)	µin RMS	°F	SCFM
to:	N/mm Circ	mm	Pascal Bar	µm RMS	°C	SLPM
Multiply English Units by:	.1751	25.4	6.895 x 10 ³ 68.95 x 10 ³	.025	C = 5/9 (F-32°)	28.3

SURFACE FINISH EQUIVALENTS:

µin. RMS	16	32	64
µm RMS	0.4	0.8	1.6

Glossary of Terms and Abbreviations

° C: degrees Celcius

° F: degrees Fahrenheit

AMS: Aerospace Material Specification

AS: Aerospace Standard

Back Height: The axial height of the closed, or back, side of an E-Seal.

Back Support: The diametral hoop restraint provided by the cavity.

circ: circumference

Convolution: The fold, or bend, of material between the legs of an E-Seal; convolutions are counted by looking in from the open side of the E shape.

Convolution Depth: The radial dimension of the convolution; its length.

Free Height: The axial dimension of a seal's cross-section (C-, E-, U-, etc.) in its free state.

Gap: The axial dimension separating the back convolutions of an E-Seal cross-section.

I.D.: inner diameter

in.: inch

lbs.: pounds

Leg: A seal section's outermost radial extension.

Leg Length: The radial dimension of a seal section's leg.

Line Contact: The sealing area coated by a radiused vs. flat seal leg.

Max: maximum

Mean Seal Diameter: The average between the seal O.D. and seal I.D.

MIL: Military Specification

Min.: minimum

MS: Military Standard

O.D.: outer diameter

PCI: pounds per circumferential inch of seal

Primary Sealing Line: The Sealing Line Closest to the open side of an E-Seal, at which sealing occurs.

psi: pounds per square inch

R: radius

SAGBOE: Acronym for *Stress Accelerated Grain Boundary Oxidation Embrittlement*; a phenomenon by which the grain boundaries of a highly stressed material experience accelerated oxidation at elevated temperatures, eventually leading to cracking of the material at those grain boundaries.

SCFM: Standard cubic feet per minute

Sealing Line: The point on a seal which contacts a cavity sealing surface around the entire circumference.

SLPM: standard liters per minute

Snap-Fit: The fit of a seal in its cavity whereby the seal remains installed within the cavity, regardless of orientation; achieved by out-of-rounding the seal. This type of fit is especially helpful with "blind" installations.

Springback: The difference between the compressed axial seal height and the released axial height following compression.

Stress Relaxation: The reduction of residual stress in a seal as a result of exposure to elevated temperatures.

Instructions for completing drawing forms.

All forms are originals, please photocopy before use. Do not write in grey areas.

Now that you have selected a seal part number, please complete the corresponding drawing form and fax it to the number on the drawing with your inquiry.

Complete the material thickness corresponding to your selection part number here.

From the P/N selection section corresponding to your seal, fill in the seal diameter and free height here.

REVISIONS

LTR	DATE	ECO NO	APPROVAL

SEAL DIMENSIONS

AVG OD	AVG MIN ID	FREE HEIGHT
- A -	- B -	- C -
SEE NOTE (Δ)	SEE NOTE (Δ)	
BEFORE PLATING		
AFTER PLATING		

NOTES:

- TIG welding prior to forming permitted per PS 85613, class C.
- Average dimension determined by 360° circumferential measurement.
- Individually package per standard internal methods.
- Mark each package as specified on sales order.
- Sealing surfaces to conform to QCS 85345.
- Plating required over this area as specified per PS 85681.
- Plating optional and may be incomplete in this area.

CAVITY DETAILS

Cavity Height: ± _____

Cavity O.D.: ± _____

Cavity I.D.: _____ MAX

Cavity Max Corner Radius: R. _____ MAX TYP

MATERIAL: _____

HEAT TREATMENT: _____

PLATING: _____ THICK

GEOMETRIC TOLERANCES TO ASME Y14.5M
UNLESS OTHERWISE SPECIFIED DIMENSIONS ARE IN INCHES

TOLERANCES ON LINEAR DIMENSIONS			ANGLES
.X	.XX	.XXX	± 2°
±	± .01	± .005	

EATON Eaton Corporation
11642 Old Baltimore Pike, Beltsville, Maryland 20705-1294
Phone (301) 937-4000 • Fax (301) 937-0134

C-SEAL™ OD FACE TYPE INTERNAL PRESSURE

CHECKED _____

DRAWN _____

APPROVED _____

CODE IDENT NO 15284

DWG SIZE A

DRAWING NO 61 - - - C

SCALE: NONE

SHEET 01 OF 01

Fill in the cavity details corresponding to the selected part number here.

Write in your material choice here.

For C-Seals only:

Enter Full or none.
(See P/N selection for details.)

For C-Seals only:

If you would like plating enter plating and thickness here. If no plating required, enter NONE.

After completing the form, fax to this number.

Fill in your part number here.

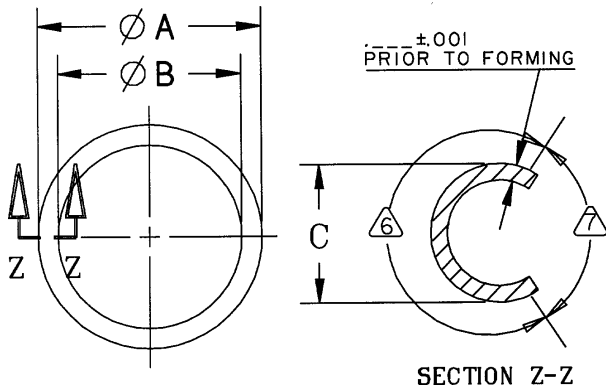

REVISIONS			
LTR	DATE	ECO NO	APPROVAL

SEAL DIMENSIONS			
	AVG OD - A - SEE NOTE ②	AVG MIN ID - B - SEE NOTE ②	FREE HEIGHT - C -
BEFORE PLATING	-----	-----	-----
AFTER PLATING			

NOTES:

1. TIG welding prior to forming permitted per PS 85613, class C.
- ②. Average dimension determined by 360° circumferential measurement.
3. Individually package per standard internal methods.
4. Mark each package as specified on sales order.
5. Sealing surfaces to conform to QCS 85345.
- ⑥. Plating required over this area as specified per PS 85681.
- ⑦. Plating optional and may be incomplete in this area.

CAVITY DETAILS

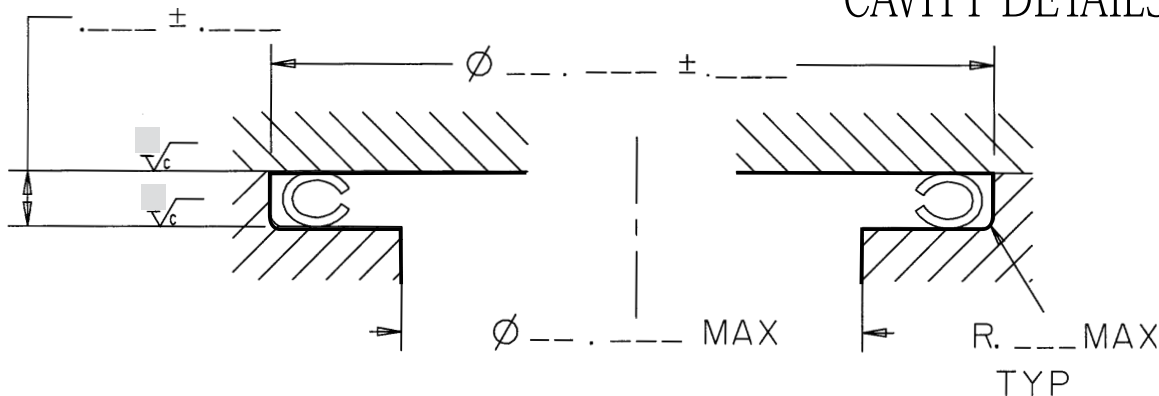

MATERIAL: _____

HEAT TREATMENT: _____

PLATING: _____ THICK

GEOMETRIC TOLERANCES TO ASME Y14.5M
UNLESS OTHERWISE SPECIFIED
DIMENSIONS ARE IN INCHES



Eaton Corporation
11642 Old Baltimore Pike, Beltsville, Maryland 20705-1294
Phone (301) 937-4010 • Fax (301) 937-0134

TOLERANCES ON			
LINEAR DIMENSIONS			ANGLES
.X	.XX	.XXX	± 2°
±	± .01	± .005	

C-SEAL™ **OD FACE TYPE**
INTERNAL PRESSURE

CHECKED _____

DRAWN _____

CODE IDENT NO
15284

DWG SIZE
A

DRAWING NO
61 - - - - C

APPROVED _____

SCALE: NONE

SHEET 01 OF 01

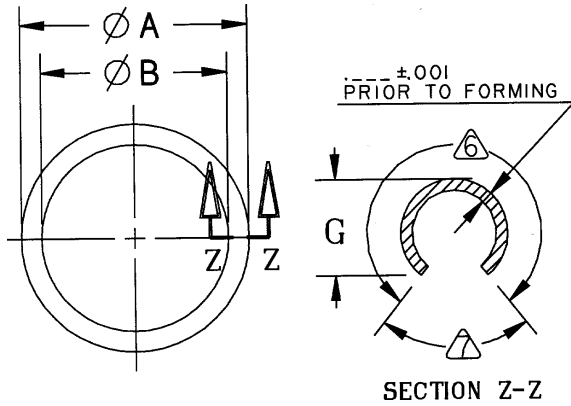

REVISIONS			
LTR	DATE	ECO NO	APPROVAL

SEAL DIMENSIONS			
	AVG OD - A - SEE NOTE (2)	AVG MIN ID - B - SEE NOTE (2)	AXIAL HEIGHT - G -
BEFORE PLATING	-----	-----	MAX
AFTER PLATING			

NOTES:

- TIG welding prior to forming permitted per PS 85613, class C.
- Average dimension determined by 360° circumferential measurement.
- Individually package per standard internal methods.
- Mark each package as specified on sales order.
- Sealing surfaces to conform to QCS 85345.
- Plating required over this area as specified per PS 85681.
- Plating optional and may be incomplete in this area.

CAVITY DETAILS

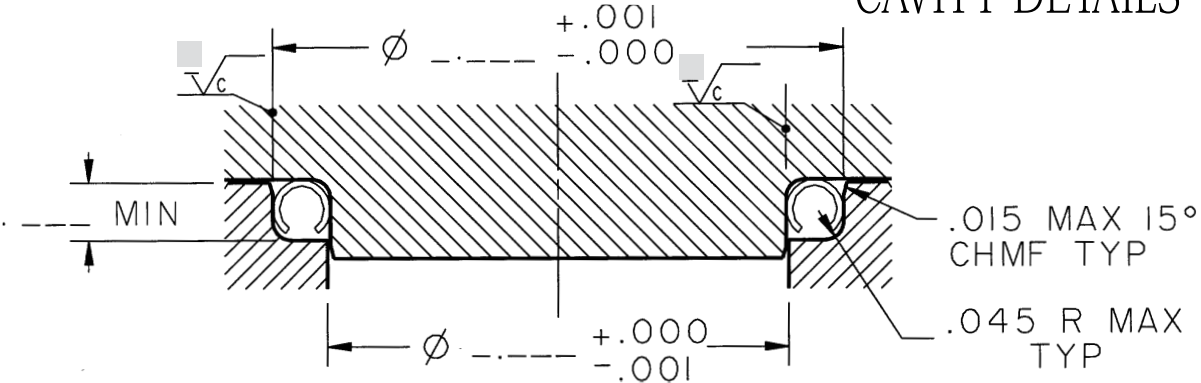

MATERIAL:

HEAT TREATMENT:

PLATING: _____ THICK

GEOMETRIC TOLERANCES TO ASME Y14.5M
UNLESS OTHERWISE SPECIFIED
DIMENSIONS ARE IN INCHES



Eaton Corporation
11642 Old Baltimore Pike, Beltsville, Maryland 20705-1294
Phone (301) 937-4010 • Fax (301) 937-0134

TOLERANCES ON			
LINEAR DIMENSIONS			ANGLES
.X	.XX	.XXX	± 2°
±	± .01	± .005	

C-SEAL™ **OD RADIAL TYPE**

CHECKED _____

DRAWN _____

APPROVED _____

CODE IDENT NO
15284

DWG SIZE
A

DRAWING NO
62 - - - -

SCALE: NONE

SHEET 01 OF 01

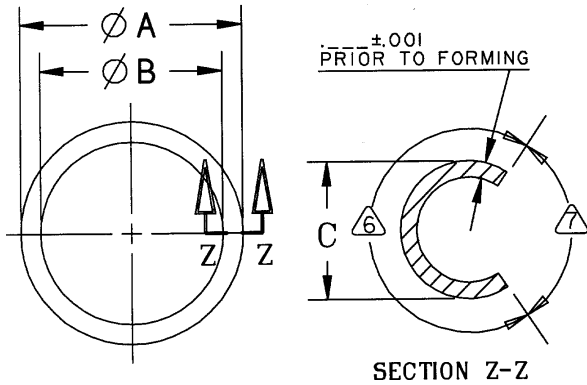

REVISIONS			
LTR	DATE	ECO NO	APPROVAL

SEAL DIMENSIONS		
AVG MAX OD - A - SEE NOTE ②	AVG ID - B - SEE NOTE ②	FREE HEIGHT - C -
BEFORE PLATING	-----	-----
AFTER PLATING	-----	-----

NOTES:

1. TIG welding prior to forming permitted per PS 85613, class C.
- ② Average dimension determined by 360° circumferential measurement.
3. Individually package per standard internal methods.
4. Mark each package as specified on sales order.
5. Sealing surfaces to conform to QCS 85345.
- ⑥ Plating required over this area as specified per PS 85681.
- ⑦ Plating optional and may be incomplete in this area.

CAVITY DETAILS

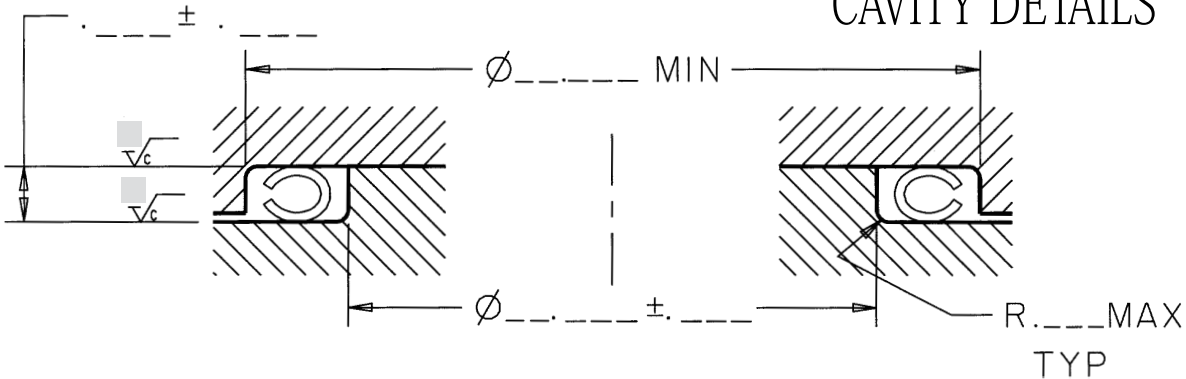

MATERIAL:

HEAT TREATMENT:

PLATING: _____ THICK

GEOMETRIC TOLERANCES TO ASME Y14.5M
UNLESS OTHERWISE SPECIFIED
DIMENSIONS ARE IN INCHES

TOLERANCES ON			ANGLES ± 2°
LINEAR DIMENSIONS			
.X	.XX	.XXX	± 2°
±	± .01	± .005	



Eaton Corporation
11642 Old Baltimore Pike, Beltsville, Maryland 20705-1294
Phone (301) 937-4010 • Fax (301) 937-0134

C-SEAL™ ID FACE TYPE
EXTERNAL PRESSURE

CHECKED _____

DRAWN _____

CODE IDENT NO
15284

DWG SIZE
A

DRAWING NO
63 - -C

APPROVED _____

SCALE: NONE

SHEET 01 OF 01

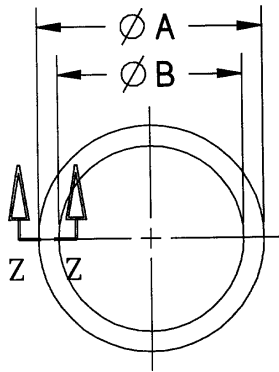

$\pm .001$
PRIOR TO FORMING

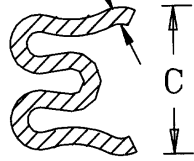

SECTION Z-Z

REVISIONS			
LTR	DATE	ECO NO	APPROVAL

SEAL DIMENSIONS		
AVG OD - A -	AVG MIN ID - B -	FREE HEIGHT - C -
SEE NOTE ②	SEE NOTE ②	
---	---	---
---	---	---

NOTES:

1. TIG welding prior to forming permitted per PS 85613, class C.
- ② Average dimension determined by 360° circumferential measurement.
3. Individually package per standard internal methods.
4. Mark each package as specified on sales order.

CAVITY DETAILS

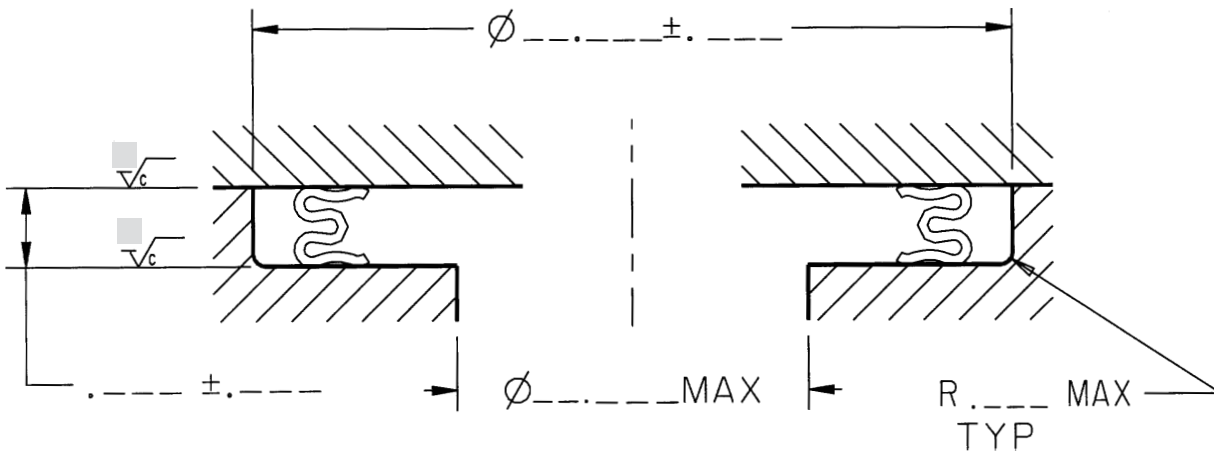

MATERIAL:

HEAT TREATMENT:

GEOMETRIC TOLERANCES TO ASME Y14.5M
UNLESS OTHERWISE SPECIFIED
DIMENSIONS ARE IN INCHES



Eaton Corporation
11642 Old Baltimore Pike, Beltsville, Maryland 20705-1294
Phone (301) 937-4010 • Fax (301) 937-0134

TOLERANCES ON			ANGLES $\pm 2^\circ$
LINEAR DIMENSIONS			
.X	.XX	.XXX	$\pm 2^\circ$
\pm	$\pm .01$	$\pm .005$	

E-SEAL™ **OD FACE TYPE**
INTERNAL PRESSURE

CHECKED

DRAWN

CODE IDENT NO
15284

DWG SIZE
A

DRAWING NO
6 - - - - C

APPROVED

SCALE: NONE

SHEET 01 OF 01

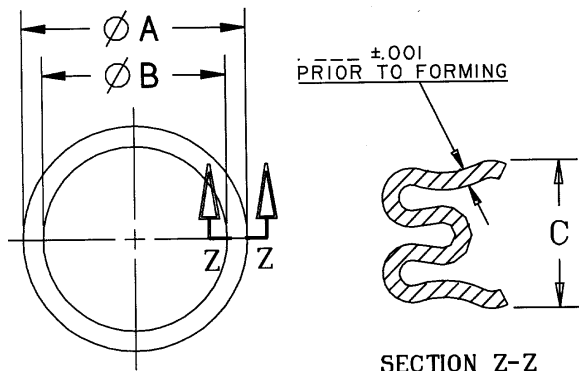

REVISIONS			
LTR	DATE	ECO NO	APPROVAL

SEAL DIMENSIONS		
AVG MAX OD - A -	AVG ID - B -	FREE HEIGHT - C -
SEE NOTE ②	SEE NOTE ②	

NOTES:

1. TIG welding prior to forming permitted per PS 85613, class C.
- ② Average dimension determined by 360° circumferential measurement.
3. Individually package per standard internal methods.
4. Mark each package as specified on sales order.

CAVITY DETAILS

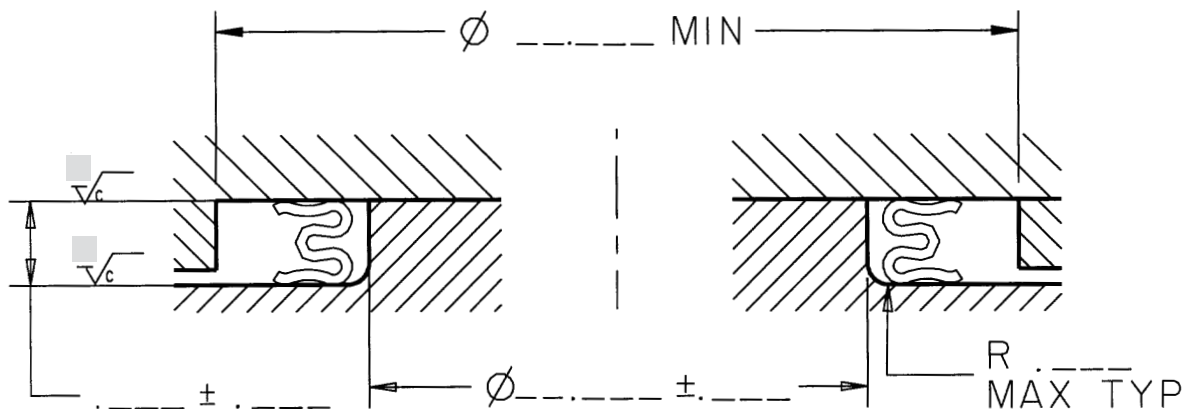

MATERIAL:

HEAT TREATMENT:

GEOMETRIC TOLERANCES TO ASME Y14.5M
UNLESS OTHERWISE SPECIFIED
DIMENSIONS ARE IN INCHES



Eaton Corporation
11642 Old Baltimore Pike, Beltsville, Maryland 20705-1294
Phone (301) 937-4010 • Fax (301) 937-0134

TOLERANCES ON			ANGLES $\pm 2^\circ$
LINEAR DIMENSIONS			
.X	.XX	.XXX	$\pm 2^\circ$
\pm	$\pm .01$	$\pm .005$	

E-SEAL™ ID FACE TYPE
EXTERNAL PRESSURE

CHECKED

DRAWN

CODE IDENT NO
15284

DWG SIZE
A

DRAWING NO
6 - - - - C

APPROVED

SCALE: NONE

SHEET 01 OF 01

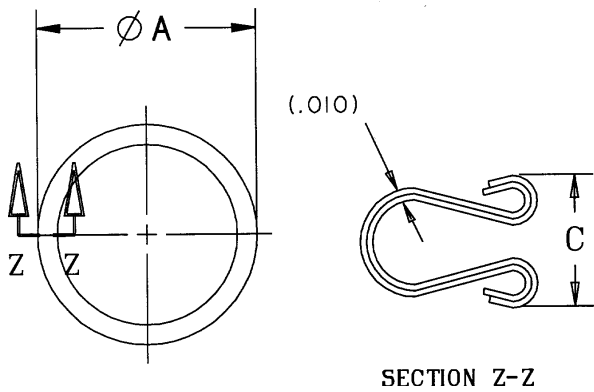

REVISIONS			
LTR	DATE	ECO NO	APPROVAL

SEAL DIMENSIONS	
AVG OD - A - SEE NOTE 2	FREE HEIGHT - C -

NOTES:

1. TIG welding prior to forming permitted per PS 85613, class C.
2. Seal is out-of-round for snap fit.
3. Individually package per standard internal methods.
4. Mark each package as specified on sales order.

CAVITY DETAILS

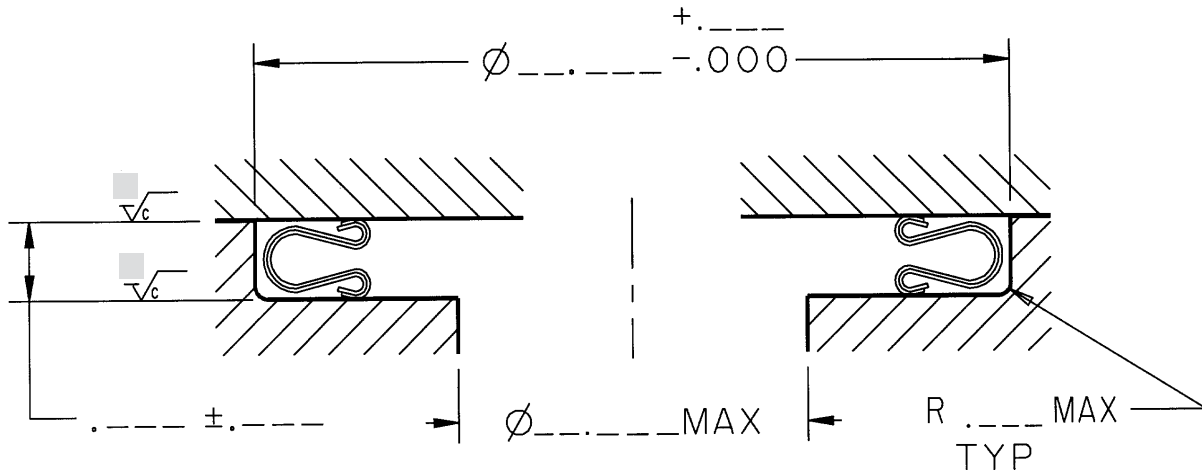

MATERIAL:
INCONEL 718 PER AMS 5596 OR 5589
2 PLIES .005 ± .0005 THICK

HEAT TREATMENT:
PER PS 0880, SECTION 10

GEOMETRIC TOLERANCES TO ASME Y14.5M
UNLESS OTHERWISE SPECIFIED
DIMENSIONS ARE IN INCHES



Eaton Corporation
11642 Old Baltimore Pike, Beltsville, Maryland 20705-1294
Phone (301) 937-4010 • Fax (301) 937-0134

TOLERANCES ON			
LINEAR DIMENSIONS			ANGLES
.X	.XX	.XXX	± 2°
±	± .01	± .005	

U-PLEX™ SEAL **OD FACE TYPE**
INTERNAL PRESSURE

CHECKED

DRAWN

CODE IDENT NO
15284

DWG SIZE
A

DRAWING NO
13 - - - -

APPROVED

SCALE: NONE

SHEET 01 OF 01

Eaton's Application Sheet

Fax: (301) 902-3602**Email: quotes-eaton-beltsville@eaton.com**

Use this form if you could not find a seal to meet your application's requirements or would like further assistance with your application. Send this cover sheet along with the requested supporting information to Eaton at the number above. Please be as detailed as possible.

From:

Name	Title
------	-------

 Company and Address (Please include mail stop number if applicable)

Telephone Number	Fax Number
------------------	------------

Today's date:	Total # of pages being sent
---------------	-----------------------------

Please provide Eaton with a sketch of your application's cavity. Be sure to include all known information requested below:

- a. Location of the centerline
- b. Cavity outer and inner diameters, with manufacturing tolerances ($\varnothing A$, $\varnothing B$)
- c. Cavity axial height (F), with manufacturing tolerances
- d. Axial and radial thermal excursions or growths. For radial growths, indicate whether this value is radial or diametral, and include mechanical effects.
- e. Cavity materials and/or thermal expansion coefficients
- f. Possible sealing surfaces and corresponding allowable load-to-compress requirements and/or limitations.
- g. Maximum cavity corner radii, chamfers, and edgebreaks (R. MAX., etc.)
- h. Cavity surface finish (all mating surfaces)
- i. Sealing medium. Indicate values and locations of high and low pressures.
- j. Maximum operating temperature. If temperature is greater than 1300°F, indicate total time spent above 1300°.
- k. Expected and/or required life in hours or cycles. (If possible, both.)
- l. Leakage requirements (if known)

Eaton Corporation
Aerospace Operations
3 Park Plaza, Suite 1200
Irvine, California 92614
Phone: (949) 253-2117
Fax: (949) 253-2111
www.aerospace.eaton.com

Eaton Corporation
Conveyance Systems Division
300 South East Avenue
Jackson, Michigan 49203-1972
Phone: (517) 787-8121
Fax: (517) 787-5758

Eaton Corporation
Conveyance Systems Division
Route 2 Box 361
Meadowbrook Road
Eastanollee, Georgia 30538
Phone: (706) 779-3351
Fax: (706) 779-2638

Eaton Corporation
Conveyance Systems Division
11642 Old Baltimore Pike
Beltsville, Maryland 20705
Phone: (301) 937-4010

Eaton Corporation
Conveyance Systems Division
15 Pioneer Ave.
Warwick, Rhode Island 02888
Phone: (401) 781-4700

Eaton Corporation
Conveyance Systems Division
671 W. 17th Street
Costa Mesa, California 92627
Phone: (949) 548-3421
Fax: (949) 752-2997

Eaton LTD
Conveyance Systems Division
Broad Ground Road
Lakeside
Redditch
Worcs B98 8YS
England
Phone: (44) 152-751-7555
Fax: (44) 152-751-7556

Eaton S.A.
Conveyance Systems Division
2 Rue Lavoisier BP 54 78310
Coignieres, France
Phone: (33) 1-30-69-3000

Eaton LTD
Conveyance Systems Division
Chemin De Pau
64121 Serres-Castet
France
Phone: (33) 559-333-864
Fax: (33) 559-333-865

Eaton LTD
Conveyance Systems Division
Posttack 1026
Carl -Benz-Strasse 9
D-82205 Gilching
Germany
Phone: 49 (0) 8105-750
Fax: 49 (0) 8105-7555

Vickers Systems Pte Ltd
Conveyance Systems Division
Lot 512, Jalan Delima, Batamindo
Industrial Park
Batam 29433, Indonesia
Phone: (62) 611823



©2007 Eaton Corporation
Teflon® is a registered trademark of DuPont.
Inconel® is a registered trademark of
International Nickel Co., Inc.
All Rights Reserved
Printed In USA
Copying or Editing is Forbidden
Form No. TF100-35
December 2007